

Automatic Power Backup System for Quad Power Sources and Real-Time Reporting

Mayeel.A¹, Sindhukavi.J²

P.G student, Communication Systems (ECE), Idhaya Engineering College for Women, Chinnasalem, India.¹
Assistant Professor, Department of Electronics and Communication Engineering, Idhaya Engineering College for Women, Chinnasalem, India.²

Abstract: The demand for electricity is increasing every day and frequent power cut is causing many problems in various areas like industries, hospitals and houses. An alternative arrangement for power source switching is thus desirable. Uninterrupted automatic power changers are easily available for two sources but with developing power generation systems like solar power, wind power, generators etc. we have no system to switch over three or four power systems. We work here to create an automatic system of switching over four different power sources. As the power supply goes missing, the system automatically changes over next available power source. The main objective of this project is to provide uninterrupted power supply to a load and to provide real time reporting. It selects the supply source automatically from any available one out of 4 such as: mains, generator, and inverter and solar in the absence of power supply.

Keywords: Power Source; Automatic Power Changers; Uninterrupted; Generator

I. INTRODUCTION

The invention of electricity and its advancements in the field of electrical engineering has made electrical energy so vast in its applications. A modern house today, cannot be said to be one if it has no use for electricity. This is because most of the items required for making life fit and comfortable in a home functions with electricity. Electrical appliances like water heaters, radios, televisions, fans, water pumps etc. all have absolute need for electricity. Unfortunately though the poor availability of public utility power in Nigeria has pushed her citizens to seek alternatives and in dependent means of electricity. This has resulted in individuals buying wind turbines, solar panels, generating sets and so on. Unavoidably this requires careful selection of the one to be ON to their use alternative power or public power utility. Sequel to this, phase absence is a very common and severe problem in any industry, home or office.

II. EXISTING SYSTEM

Automatic changers which were traditionally used for generators and main current i.e. Rotor based manual selection of power source. The main problems associated with a manual switching system are as follows: interrupted power supply, device damage due to frequent commutations, possible causes of fire outbreak due to switching sparks and frequent high maintenance cost due to changeover action and wear and tear of mechanical parts.

III. OVERVIEW OF THE PROPOSED SYSTEM

Here a new system is proposed to surmount the demerits of existing system. It includes the design, construction and operation of a program controlled power change over system.

Many times one or two phases may not be live in the three phase supply, because of this some electrical appliances will be ON in one room and OFF in another room. This project is also designed to check the availability of any live phase, and the load will be connected to the live phase only. This feat is achieved with AT89C51 MCU. This controller continuously checks for live condition of all the phases connected to it, and the controller connects the load to the active phase using a relay. The relay is driven with a transistor. If two or three phases are live, the phase will be connected to the phase that is ON only and automatically transferred to the phase that is ON in the event of a main outage or from generator back to main when restored. An LCD is provided to display the status of the phase condition. Contrast control preset is given for LCD contrast control.

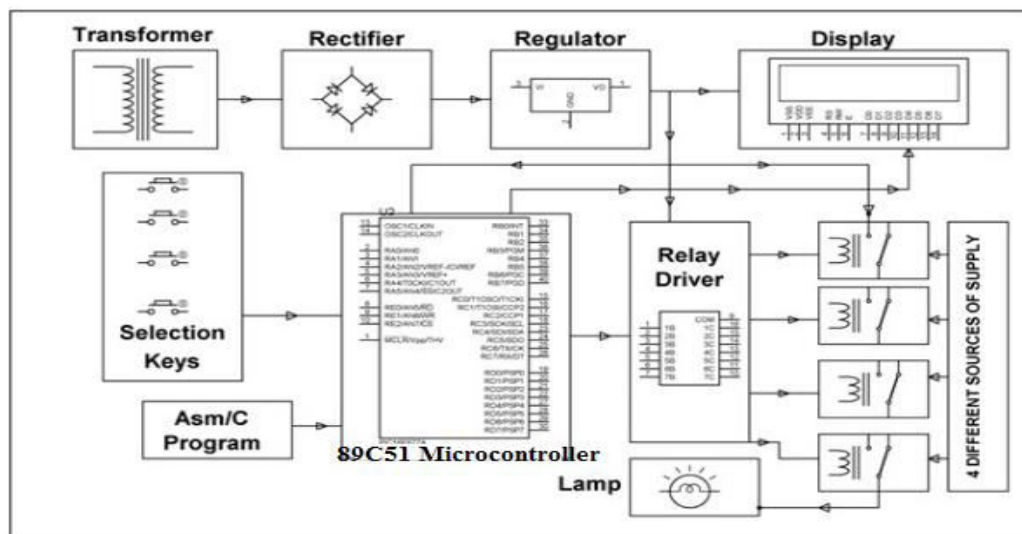

Fig. 1 Block diagram of the overall proposed system

Furthermore the project uses a regulated 12V, 500mA power supply. Bridge type full-wave rectifier was used to rectify the ac output of the secondary 230/12V step down transformer. Rectification converts AC voltage into DC voltage and is achieved using full bridged diode. Bridged rectification gives full wave and was used to get positive voltage controlled circuit (VCC) and negative ground (GND) polarization.

In addition due to problems incurred over interrupted power supply, this led to the discovery of three phase intelligent switching system which makes the selection process a lot stress free, efficient and cost effective. The three-phase intelligent switching system makes our network infrastructure smarter. Intelligent switching systems are in a giving phase in that companies are continually developing solutions that will make network systems smarter in the future. The demand for sensitive systems which are able to monitor the violent and devastating effect of fire and vandals at homes, offices etc. have increased. This led to the idea of an intelligent switching system which has the ability to monitor, control and switch between phases. It also provides the comfort of starting a standby generator when there is power failure from the mains (PHCN) without the aid of an operator. The switching between the mains and the generator occurs in micro seconds

Mode of operation

This project employs four switches to demonstrate / activate respective failure of the source of power supply. When any of the switches is pressed, it shows the absence of that particular source. Switches are connected to the microcontroller as input signals. A microcontroller of the 89C51/audrino family is used. The output of the microcontroller is given to the relay driver IC, which switches appropriate relay to maintain uninterrupted supply to the load. Output is observed using a lamp drawing power from the mains initially. On the failure of the mains supply (which is actuated by pressing appropriate switch) the load gets supply from the next available source i.e. an inverter. If the inverter also fails, it switches over to the next available source, and so on. The current status, like which source is supplying power to the load is also displayed on an LCD. As it is not feasible to provide all 4 different sources of supply, one source with an alternate parallel arrangement is provided to get the same function for demo purposes. However 4 different sources if available they can be used.

IV. IMPLEMENTATION

The process in the implementation is that the power can be automatically switched over multiple sources. Also the real-time reporting is implemented with LCD Display. By using this we can get uninterrupted power supply even in absence of AC Mains power.

V. RELATED WORKS

Microcontroller

Circumstances that we find ourselves in today in the field of microcontrollers had their beginnings in the development of technology of integrated circuits. This development has made it possible to store hundreds of thousands of transistors into one chip. That was a prerequisite for production of microprocessors, and the first computers were made by adding external peripherals such as memory, input-output lines, timers and other. Further increasing of the volume of the package resulted in creation of integrated circuits. These integrated circuits contained both processor and peripherals. That is how the first chip containing a microcomputer, or what would later be known as a microcontroller came about.

LCD Display

LCD (Liquid Crystal Display) screen is an electronic display module and find a wide range of applications. A 16x2 LCD display is very basic module and is very commonly used in various devices and circuits. These modules are preferred over seven segments and other multi segment LEDs. The reasons being: LCDs are economical; easily programmable; have no limitation of displaying special & even custom characters (unlike in seven segments), animations and so on.

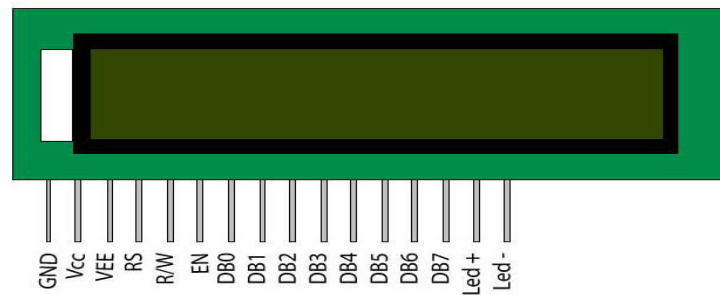

Fig. 2 LCD Display

Channel Relay

This is a 5V 4-channel relay interface board, and each channel needs the 15 to 20mA driver current. It can be used to control various appliances and equipment with large current. It is equipped with high-current relays that work under AC250V 10A or DC30V 10A. It has a standard interface that can be controlled directly by microcontroller. There are four relays in one board. Each relay has a Normally Open (NO) and a Normally Closed (NC) contact.



Fig. 3 Channel Relay

Power supply

A power supply provides a constant output regardless of voltage variations. "Fixed" three-terminal linear regulators are commonly available to generate fixed voltages of plus 3 V, and plus or minus 5 V, 9 V, 12 V, or 15 V when the load is less than about 7 amperes. The "78xx" series (7805, 7812, etc.) regulate positive voltages while the "79xx" series (7905, 7912, etc.) regulate negative voltages. Often, the last two digits of the device number are the output voltage; eg, a 7805 is a +5 V regulator, while a 7915 is a -15 V regulator. The 78xx series ICs can supply up to 1.5 Amperes depending on the model.

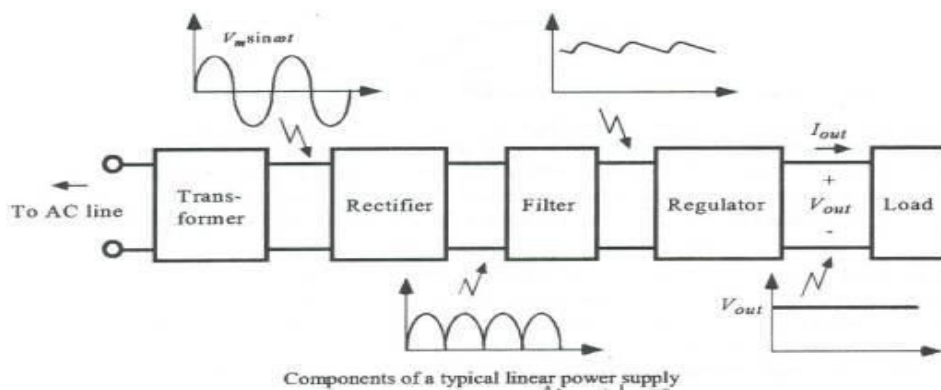

Fig. 4 Block diagram of the power supply.

VI. RESULT AND OUTPUT DISCUSSIONS

Each module of the system was implemented, tested and integrated before testing the entire system. Here the input from the four sources is given to the microcontroller. Then the output of the microcontroller is given to the Relay which maintains the uninterrupted power supply to the load. If Power Mains gets failed then the load automatically gets supply from the next available sources with high voltage. Finally the current status is displayed on the LCD Display.

VII. HARDWARE MODULES

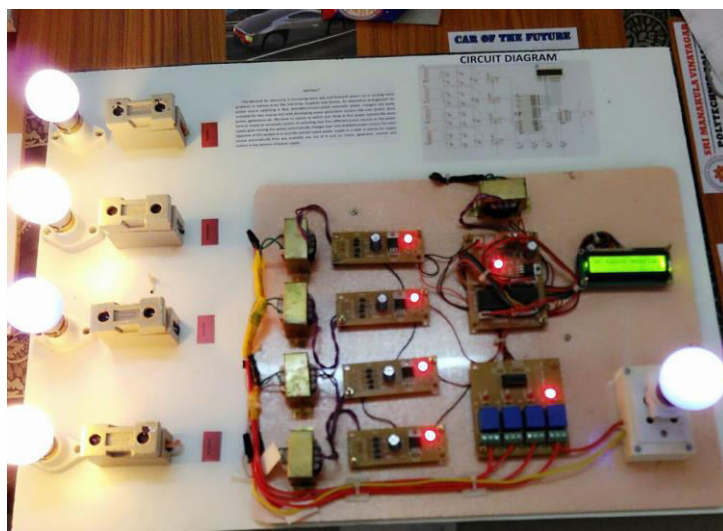

Fig. 5 Output Representation

VIII. CONCLUSION

The design and implementation of programmable power changeover has been implemented in this paper. After designing each key module, the program was written in assembly language and tested to ensure that the module is responding to the desired output on the display panel. The technology will upon the automation of the existing change over system, add some intelligence to automatic power changeover by allowing user to choose the mode they want their automatic systems to operate on. The present system has improved the

existing automatic and manual power change over. This project is designed to check the availability of any live phase, and the load will be connected to the live phase only. In addition due to problems incurred over interrupted power supply, this led to the discovery of three-phase smart switching system which makes the selection process a lot stress free, efficient and cost effective.

ACKNOWLEDGMENT

I thank Mr.Raushan Kumar Singh, SPECTRUM SOLUTIONS, Pondicherry to help me in creating this paper with his Sincere Guidance and Technical support in the field of power production.

I thank my guide Ms. Sindhukavi.J, A.P/ECE, Idhaya Engineering College for women, Chinnasalem, for her great support. The help of Mrs.Poovizhi, HOD, Department of Electronics and Communication Engineering, Idhaya Engineering College for Women, is really immense and once again I thank for her great motivation.

I thank IECW, Salem for providing me such a standard educational environment so that I am able to understand the minute concepts in the field of Engineering and Technology.

REFERENCES

- [1] M. Shams, A. Chidanandan, W. Pan, and M. A. Bayoumi, "NEDA: A low-power high-performance DCT architecture," *IEEE Trans. Signal Process.*, vol. 54, no. 3, pp. 955–964, 2006.
- [2] Loeffler, A. Lightenberg, and G. S. Moschytz, "Practical fast 1-D DCT algorithm with 11 multiplications," in *Proc. Int. Conf. Acoust., Speech, Signal Process. (ICASSP)*, May 1989, pp. 988–991.
- [3] M. Jridi, P. K. Meher, and A. Alfalou, "Zero-quantised discrete cosine transform coefficients prediction technique for intra-frame video encoding," *IET Image Process.*, vol. 7, no. 2, pp. 165–173, Mar. 2013.
- [4] S. Bouguezel, M. O. Ahmad, and M. N. S. Swamy, "Binary discrete cosine and Hartley transforms," *IEEE Trans. Circuits Syst. I, Reg. Papers*, vol. 60, no. 4, pp. 989–1002, Apr. 2013.
- [5] F. M. Bayer and R. J. Cintra, "DCT-like transform for image compression requires 14 additions only," *Electron. Lett.*, vol. 48, no. 15, pp. 919–921, Jul. 2012.
- [6] R. J. Cintra and F. M. Bayer, "A DCT approximation for image compression," *IEEE Signal Process. Lett.*, vol. 18, no. 10, pp. 579–582, Oct. 2011.
- [7] S. Bouguezel, M. Ahmad, and M. N. S. Swamy, "Low-complexity 8 8 transform for image compression," *Electron. Lett.*, vol. 44, no. 21, pp. 1249–1250, Oct. 2008.

AUTHOR'S BIOGRAPHY



Mayeel. A was born in Sembadakurichi, Villupuram (D.T), Tami Nadu, India on 02 July 1993. She received her Graduate degree in Electronics and Communication Engineering from Idhaya Engineering College for Women, Chinnasalem in 2014. Currently she is pursuing her Post Graduate degree under the department of Communication Systems from Idhaya Engineering College for Women, Chinnasalem.



Ms. Sindhukavi.J was born in Veliyampakkam, Villupuram (D.T), Tamil Nadu, India on 23 April 1990. She is currently working as Assistant Professor for the department of Electronics and Communication Engineering in Idhaya Engineering College for Women, Chinnasalem. She had published many papers during the period of working and also had given many guest lectures.