

Secured Electronic Voting Machine using Biometric

[1] Pavaiyarkarasi.R,[2] Ranjana.B, [3] Rogini.A,[4] Saranya.A

^[1] Assistantt.Professor ^{[2][3][4]}UG Student, Department of Electronics and Communication Engineering

T.J.S Engineering College

^[1] pavaipanmeer@gmail.com, ^[2] ranjanababu312@gmail.com, ^[3] roginipriya20@gmail.com, ^[4] saranyaeece059@gmail.com

ABSTRACT

In democratic societies, voting is an important tool to collect and re-act people thinking's. Traditionally, voting is conducted in centralized or distributed places called polling booths. Voters go to polling booths and cast their votes under the supervision of authorized parties. Then the votes are counted manually once the election has completed. With the rapid growing development of computer technology and cryptographic methods. The electronic voting systems can be employed that replace the incident and most importantly error-prone human Component.

Our project proposes and implements a simple and secured method of polling vote by using biometric. Due to the changes occurred in the technology, so many advancements were introduced in the field of voting. The improvisations aim at increasing the flexibility security, reliability, scalability of the model and provide even through SMS also. But this electronic voting machine is a unique and new concept which saves a lot of time and avoids the false voting by a false person. In this system, the user has to use his fingerprint to poll the authenticated vote.

The finger print module was already stored in the government database. Hence this project provides a best solution to avoid the false voting. The electronic voting machine was connected with the computer. The computer is having the full database list of the peoples who is having the eligibility to vote. For each polling the corresponding person identity was deleted. So it avoids the false voting. A touch screen is used, so it is user friendly. A printer is also used to provide a confirmation sheet for the voter who polls the authenticated vote. GSM module is used for sending result to the corresponding authority.

Index Terms: GSM MODULE, FINGER PRINT READER, ARM 7 CORTEX,

I.INTRODUCTION

To increase the efficiency and accuracy of voting procedures. Large number of computerized voting systems were developed to help collecting and counting the votes. Which include Lever Voting Machines, Voting based Punched Cards and Optical Mark-Sense Scanners and Direct Recording Electronic (DRE) voting systems. Even though if we are having many technologies, each and every advance

technology having some disadvantages. Such as the electronic voting machine which we are using nowadays also has few disadvantages. Voter can hear the sound produced by the electronic voting machine, but the person not getting acknowledgement after the voting. And also the man power is required to identify the person's identity. This may create some errors or electoral fraud.

II. PREVIOUS WORK

PAPER BALLOTS

A ballot is a device used to cast votes in an election. In that method they may used a piece of paper or a small ball for secret voting. Which was originally a small ball- see blackball – that is used to record decisions made by voters. Each one of the voter uses one ballot, and that ballots are not shared.

In simplest elections ballot may be a simple scrap of paper on which each voter writes in the name of a candidate. In general body or governmental elections use pre -printed to protect the secrecy of the votes. The person who votes they can casts his/her ballot in a box at a polling station. The word "ballot" is used for an election process within an organization. Such as a trade union "holding a ballot" of its members.

Drawbacks

- Need more paper to vote
- Need more time to vote
- Not suitable for blind peoples
- Need more time for counting
- Need more man power for security

LEVER VOTING MACHINES

The voter enters the machine and pulls a lever to close the curtain to unlocking the voting levers. The pollers then make his or her selection from a list of switches denoting the appropriate candidates or measures. The machine is configured to prevent over votes by locking out other candidates when one candidate's switch is flipped once the voter is finished and the lever is pulled which opens the curtain and increments the appropriate counters for each candidate and measure also the results are then hand written by the precinct officer at the conclusion of voting

Drawbacks

- Complex voting procedure
- More time to vote
- Recount of voting is not possible
- Expensive to test, complete tests are extremely rare
- Expensive to move and store,
- Difficult to test,
- Complex to maintain
- Far from secure against vote fraud.

PUNCHED CARDS

Punched card systems employ a card (or cards) and a small clipboard-sized device for recording votes. Voters punch holes in the cards (with a supplied punch device) opposite their candidate or ballot choice issue. After voting, the voter may place the ballot in a ballot box or the ballot may be fed into a computer vote tabulating device at the precinct.

Drawbacks

- Candidate names are not specified in the machine
- Confidential polling is not possible
- More security is required.

GSM MOBILE BASED INTELLIGENT POLLING SYSTEM

Votes are polled by the voters through the GSM mobile. The GSM Receiver Module, which receives votes from each voter in terms of message. Each person has unique mobile id, just like a voter id, that identify the voter's identity. Election committee provides the mobile id. The citizen who uses mobile can cast their votes through GSM mobile. For this purpose the information of candidates are predefined to voter's modem has own number that is known to every voter. When voter cast their votes on the day of Election. For this purpose voter send a message to GSM also it contains voter's mobile id and the candidate's id which he/she assign to vote. GSM modem will receive the votes, which is coming from voter's mobile equipment.

Drawbacks

There might be a false vote by the person who can built the SIM having the same number and also if the person lost his/her phone number then false voting will be possible.

III. PROPOSED APPROACH

With the aim of conducting democratic election, we proposed the system to Endeavour to improve the easy usage of the voting machine with authentication and an acknowledgement slip will provide for every polling which occurs. And a touch screen is used to give input so it is so highly easy to overcome the button problem. GSM module is used for sending result to the corresponding authority.

The following are the advantages of secure voting machine using biometric:

Security

The system is free from intentional tamper. It is not possible to hack the machine. Though this factor depends on the personnel integrity, attempts should be made to make the model as secure as possible. In this machine every user uses his/her finger print. The votes will be successful only after successful verification of their finger print.

Reliability

The machine registers the votes faithfully. A vote is never altered. A valid vote is never eliminated, from the final tally and an invalid vote is not counted. Vote counting is flawless. The final vote tally must be perfect. Most important think the votes are stored in EEPROM memory, where the numbers of votes are stored permanently.

Scalability

It is easy to use the basic design for any number of voters. A touch screen is also used to improve the scalability. The model is able to handle increasing voter participation without any stress on performance.

Flexibility

In this method the design of the system is such that it can be put to use in various polling systems, with different requirements and mechanisms.

Super sensitive circuitry(No invalid votes)

Inside the control unit, hidden from the person is an extremely sensitive circuitry that takes care of common election errors or malpractices like duplication vote. For instance, if one were to press two or more buttons simultaneously, then no votes supposed to be cast.

Even if there was a micro-second difference in the pressing of the switches and the EVM is sensitive enough to trace and identify the twitch that was press first.

Hi-tech Simplicity

To commence polling, the polling officer activates the "Ballot" switch on the control unit. The voter then has to press the button of his choice on the ballot unit. This is followed by a short beep sound, indicating that the vote has been cast. Once again, the polling officer has to press the "Ballot" switch to clear the machine for the next voter to cast his vote.

Automatic Counting

This system will count the votes automatically so the counting process will be faster and that will help to publish the result faster.

The proposed block diagram shows that the ARM Cortex-A8 processor based on the ARMv7 architecture also it has the ability to scale in speed from 600MHz to greater than

1GHz is used to control the peripherals. Other modules which are connected to the processor are follows

- Personal computer.
- A module of 16X2 dual line LCD
- Fingerprint recognition scanner
- Touch screen.
- Printer
- GSM Module

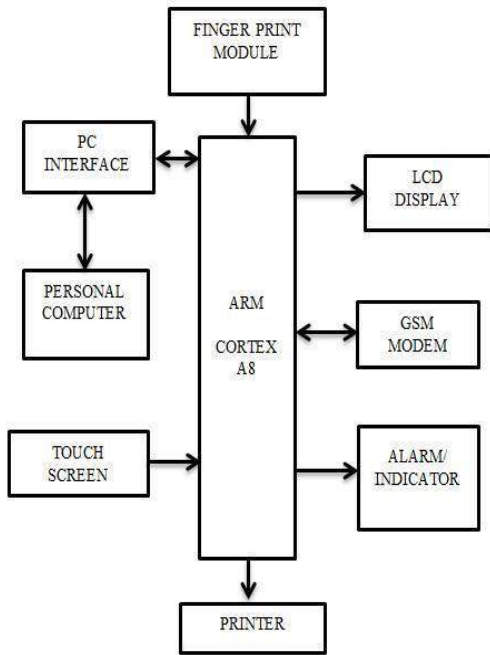

Figure: 1. BLOCK DIAGRAM SECURED ELECTRONIC VOTING MACHINE USING BIOMETRIC

The personal computer is used to collect and store the database of the peoples before voting. The ARM cortex processor is connected with a personal computer through the PC interface to access the database which is stored in the personal computer. A module of 16X2 dual line LCD is used to show the details of the processing which is happened in the voting machine. An optical finger print module is used to scan the finger print of the voters. The finger print scanner sends the scanned signal to the processor for the verification. The processor verifies the finger print with the database which is stored in the personal computer. A touch screen is used to give the input to the processor to select the candidate. An Alarm/indicator is used to produce the sound after the selection of the candidate. A printer is used to print the name of the voters and giving a receipt to the voters for the confidential polling. Finally a GSM modem is used to send the result to the corresponding authority which helps them to announce the result within short period.

IV. FLOW CHART

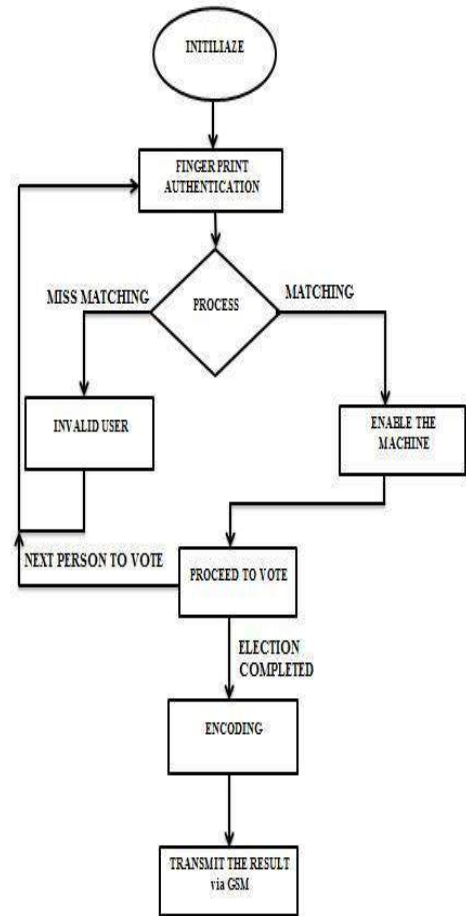

Figure: 2. TRANSMITTER

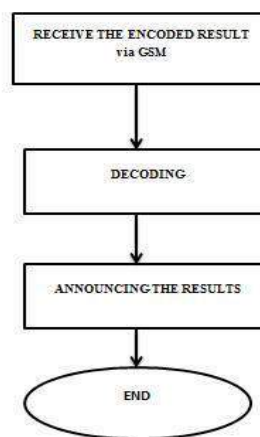

Figure: 3. RECEIVER

V.HARDWARE

FINGER PRINT MODULE

A **fingerprint** is used in narrow sense is an impression left by the friction ridges of a human finger. The fingerprints recovery from a crime scene is an important method of forensic science purpose and the Fingerprints are easily deposited on suitable surfaces (such as glass or metal or polished stone) by the natural secretions of sweat from the eccrine glands that are present in epidermal ridges.

Optical fingerprint imaging involves capturing a digital image of the print using visible light rays. In this type of sensor is essence in a specialized digital camera. Where top layer of the sensor are used to place the finger which is known as the touch surface. Down of this layer is a light-emitting phosphor layer which illuminates the surface of the finger.

Then the light is reflected from the finger passes through the phosphor layer to an array of solid state pixels (a charge-coupled device) which captures a visual image of the fingerprint which is used for authentication. But a scratched or dirty touch surface can cause a bad image of the fingerprint.

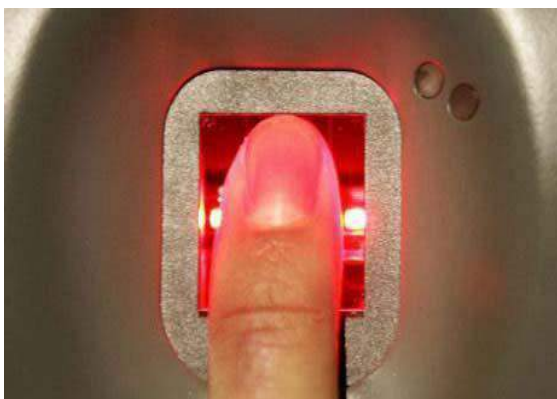

Figure: 4. FINGER PRINT MODULE

GSM MODULE

A GSM modem is a specialized type of modem which accepts a SIM card and operates over a subscription to a mobile operator like a mobile phone. The GSM modem exposes an interface that allows applications such as message to send and receive messages over the modem interfacing part.

The mobile operator charges for this message sending and receiving as if it was performed directly on a mobile phone. In order to perform these tasks, a GSM modem must support an "extended AT command set" for sending/receiving SMS, as defined in the ETSI GSM 07.05 version and 3GPP TS 27.005 specifications.



Figure: 5. GSM MODULE

VI SOFTWARE ANALYSIS

A firmware developed in C language is Programmed into the microprocessor's code memory area. The firmware control's the working of the entire hardware part. Usually the microcontrollers and the processor execute their own instructions which are in machine code.in early days the applications were written in assembly language.

The development of the huge application is very difficult by using the normal assembly language, because of their readability. Later for the fast development, the high levels languages are introduced into the embedded system C language is one of the most commonly used in the embedded system field. The ANSI C version is modified by adding specific hardware related functionality and information. The modified c language is commonly termed as embedded c. The ECLIPSE galileo is used for the development of the embedded system application development.

ECLIPSE SOFTWARE

Eclipse is a multi-language software development environment comprising a base workspace and an extensible plug-in system for customizing the environment. This is written mostly in Java. But also it can be used to develop applications in Java and by means of various plug-ins and other programming languages including

- Ada
- C++
- C
- COBOL
- Fortran
- Haskell
- JavaScript
- Perl
- PHP Python
- Ruby
- Scala
- Clojure

- Groovy
- Scheme
- Erlang.

These can also be used to develop packages for the software Mathematica and Development environments include the Eclipse Java development tools (JDT) for Java and Scala, Eclipse CDT for C/C++ and Eclipse PDT for PHP among others. A initial codebase originated from IBM Visual Age. The Eclipse software development kit (SDK), which includes the Java development tools is meant for Java developers also Users can extend its abilities by installing plug-ins written for the Eclipse Platform such as development toolkits for other programming languages and can write and contribute their own plug-in modules.

VII CONCLUSION

Our project enables secured voting and reduces man power efficiently. In this system we are introduce some new concepts and that is implementing by ARM processor. Due the immense development of Aadhar card system it can be further improved by the addition of Iris recognition system for more secured polling.

REFERENCES

- [1] Amanpreet kaur,Yashkalyani, Singh Kushagra Harila, Rahul madhesiya,"*Microcontroller Based Voice Activated Mobile Controlled Electronic Voting Machine,*" International Journal of Advanced Research in Computer and Communication Engineering Vol. 2, Issue 3, March 2013,pages 1331-1333
- [2] Firas Hazzaa, Seifedine Kadry,"*New System of E-Voting Using Fingerprint* ,"International Journal of Emerging Technology and Advanced Engineering (ISSN 2250-2459, Volume 2, Issue 10, October 2012),pages 355-363.
- [3] D. Ashok Kumar, T.Ummal Sariba Begum," *A Novel design of Electronic Voting System Using Fingerprint,*" International Journal of innovative technology & creative engineering (issn:2045-8711) vol.1 no.1 January 2011,pages 12-19
- [4] Alaguvel.R and Gnanavel.G," *Offline and Online E-Voting System with Embedded Security for Real Time,*" International Journal of Engineering Research (ISSN : 2319-6890) Volume No.2, Issue No.2, April 2013, pages 76- 82.
- [5] Diponkar Paul and Sobuj Kumar Ray," *A Preview on Microcontroller Based Electronic Voting Machine,*" International Journal of Information and Electronics Engineering, Vol. 3, No. 2, March 2013.
- [6] Gomathi.B, Veena priyadarshini.S "*Modernized Voting Machine using Finger Print Recognition,*" International Journal of Scientific & Engineering Research, Volume 4, Issue 5, May-2013.