

Air Conditioning System Using Vehicle Suspension

V.S.RAJ KAMAL¹, P.SHANTHA PRABHU², S.SATHYAMOORTHY³

^{1,2}UG Scholar Department of Mechanical, T.J.S.Engineering College, Peruvoyal, Chennai

³Assistant Professor, Department of Mechanical, T.J.S.Engineering College, Peruvoyal, Chennai

sathyamoorthias@gmail.com

Abstract—

Now a day we have required fuel efficient car. But the engine of the cars is not efficient when the load on car is high. For this purpose we have reduce the load on engine that is to run the AC and Compressor. Instead of engine power we are used the suspension system for producing compressed air and AC effect Vice- Versa. Current air-conditioning systems can reduce the fuel economy of high fuel economy vehicles. And also in previous days there is wastage of energy in suspension system that is linear motion of suspension system, which is also use for compress the air by using piston-cylinder arrangement. By using this compress air we can run AC system in the car and save fuel economy.

Keywords—Vehicle Suspension, Compress Air Production, AC System, Air Suspension

I. INTRODUCTION

In automobile the suspension system is essential to absorb shocks, vibration and bumps etc. Vehicle is run on different type road conditions such as even, uneven, rough etc. The automobile frame and body are mounted on front and rear axle through springs and shock absorbers. This is essential to damp out road shocks transmitted to the frame by the wheels when they roll over uneven road. This creates discomfort to the passengers and produces stresses in the frame and other parts of the automobile. The passenger experiences the jolts by the forward movement of the vehicle and jerks due to uneven road conditions. Even under good road condition the passenger are also subjected to bounce and roll when cornering and pitch when the front wheels are suddenly lifted or dropped in relation to rear wheels that means suspension system work continuously. Due to varying conditions of heating, ventilating, cooling and dehumidification in the atmosphere at various places, the air conditioning of automobiles is very essential. To maintain human comfort and improve internal atmosphere in an enclosed space, proper control of freshness, temperature, humidity and cleanliness of the air is required. So, in this project we are using renewable energy of

suspension system to produce air conditioning effect in automobile.

II. PROBLEM DEFINITION

Previously in conventional vehicles there is wastage of energy in vehicle suspension that is kinetic energy. This kinetic energy present during driving resulting from the movements of the suspension of the vehicle wheels.

Also in vehicle the AC is essential parameter for human comfort. But for running AC required large power. Hence the power of engine was distributed and efficiency of vehicle decreased. The AC effect was produced by compressor which was driven by engine.

To overcome these effects we have to use the linear motion of suspension system to compress the air by using piston-cylinder arrangement. By using this compress air we can run AC system in the car and save fuel. AC System Using Vehicle Suspension which have following objectives

- Recover waste energy of suspension system.
- Save fuel which is burn for working of AC
- Run AC on waste energy of suspension system.
- To increase the mileage of vehicle.

III. CONSTRUCTION AND WORKING

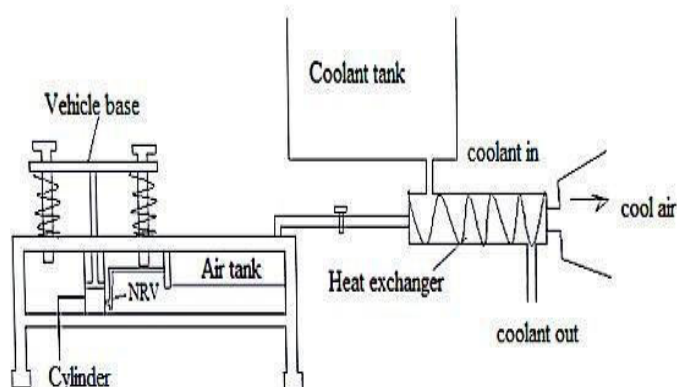

Fig.1: Working diagram of suspension recovery system

The complete diagram of vehicle suspension AC system is shown in fig. When vehicle is run on bumpy road or uneven road then suspension spring move continuously up and down. The pneumatic cylinder is installed below this spring arrangement. This pushing power is supplied to pneumatic piston and cylinder arrangement which compresses the air. This compressed air is supplied to air tank through non return valve. By the placement of non-return valve stops the back flow of pressurized air into cylinder again. That high pressurized compressed air is stored in air tank. When we want to turn on A.C. system the pressurized compressed air is supplied to parallel flow heat exchanger through nylon pipe by using knob. Storage tank is mounted at the top of the heat exchanger. In storage tank the nitrogen gas is used as refrigerant. This cold nitrogen gas refrigerant is supplied to heat exchanger. Low temperature coolant pass through the heat exchanger & also high pressurized air pass through it. Here heat exchange occurs and air temperature becomes 150 C to 300 C which is further send at the required place which is to be cooled.



Fig.2: AC System by Using Vehicle Suspension

IV. CONSTRUCTIONAL FEATURES

4.1 Air Tank



Fig.3: Air Tank

Air tank is used to store pressurize compressed air and supply this pressurize air for various use when required.

4.2 PNEUMATIC CYLINDER



FIG.3: PNEUMATIC CYLINDER

When the shock absorber is operated the spring get compressed this pushing energy is send to pneumatic piston and cylinder which compresses the air taken from surrounding.

4.3 Non Return Valve



Fig.4: Non Return valve

Model: KA-08

Max. Pressure: 1.0 Mpa

The basic function of non return valve is to allow the flow of fluid in one direction only and avoid back flow.

4.4 Parallel Flow Heat Exchanger

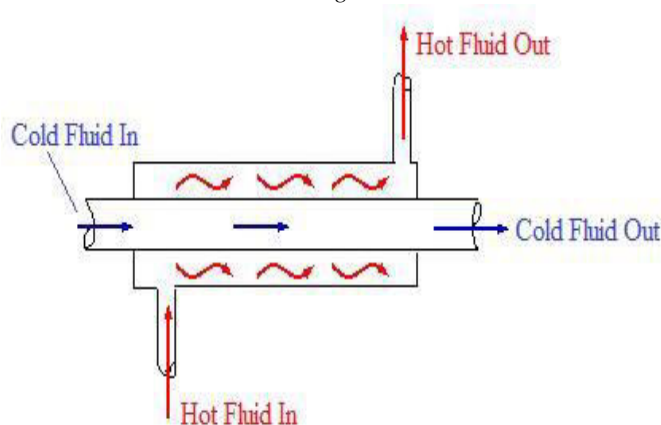

Fig.5: Parallel Flow Heat Exchanger

In parallel flow heat exchangers, the two mediums enter the exchanger at the same end, and travel in parallel to one another to the other side in this interval they exchange heat.

V. ADVANTAGES AND LIMITATIONS

5.1 Advantages

- This is a non-conventional system.
- No need fuel input.
- No external supply is required.
- This system is clean.
- Low cost of maintenance.
- Instead of nitrogen gas we can use water for cooling.
- Air production is simply by running the vehicle.

5.2 Limitations

- Leakage problems.
- For smooth & even road less compress air produced.

VI. APPLICATIONS

- Applicable in all vehicles.
- For cleaning & inflation of tubes.
- Swing machine.
- Compress air can use for pneumatic braking system.
- In stair cases.

VII. CONCLUSION

This paper is focused on energy saving mechanisms by using vehicle suspension system. This project can be very much useful for Indian conditions because of geographical sites. Taking into consideration other manmade sites like road it is well known fact that we have one of the best as well as worst road conditions available. So this kind of project is well worth regarding Indian context of view. Using of this system in vehicle we are save fuel economy.

References

- [1] Papson, A.; Creutzig, F.; Schipper, Low Compressed air vehicles: Drive-cycle analysis of vehicle performance, environmental impacts, and economic costs. *Transp. Res. Rec. J. Transp. Res. Board* 2010, 2191, 67–74.s
- [2] Atkinson, J., and Postle O., —The Effect of Vehicle Maintenance on Fuel Economy,| in *Fuel Economy of the Gasoline Engine* edited by Blackmore D. R. and Thomas A., Shell Research Limited, Thornton Research Center, Chester, United Kingdom, 1977.
- [3] Noritsugu T. —Energy Saving of a Pneumatic System (2). Energy Regenerative Control of a Pneumatic Drive System. Application to Active Air Suspension|, *Hydraulics& Pneumatics*, 1999, 38(4), pp.1-4.
- [4] Bugli, N., —Automotive Engine Air Cleaners - Performance Trends,| SAE Technical Paper 2001-01-1356,2001, doi:10.4271/2001-01-1356.
- [5] Zhang Jin-qiu, Peng Zhi-zhao, Zhang Lei, Zhang Yu, —A Review on Energy-Regenerative Suspension Systems for Vehicles| Proceedings of the World Congress on Engineering 2013 Vol III, WCE 2013, July 3 - 5, 2013, London, U.K.
- [6] G.V.Srinivasa Rao, Dr. C.J.Rao, Dr.N.HariBabu, —Heat Transfer Analysis on Shell & Tube Heat Exchangers|, vol. 2, pgs.11-26, January 2014.
- [7] Shravan H. Gawande¹, Sunil D. Wankhede¹, Rahul N. Yerrawar¹, Vaishali J. Sonawane¹, Umesh B. Ubarhande, —Design and Development of Shell & Tube Heat Exchanger|, pgs. 121-125, November 2012.