

# Railway Anti-collision System Using ARDUINO BOARD and GPS Sensors

<sup>1</sup>R.Divyapriya, <sup>2</sup>Prudvi Saidurgamadhavipriya, <sup>3</sup>M.Gayathri, <sup>4</sup>Shanmugapriya.S  
UG Scholar <sup>1,2,3</sup>, Assistant Professor<sup>4</sup>, Department of Computer Science and Engineering,  
Vel Tech High Tech Dr.Rangarajan Dr.Sakunthala Engineering College, Avadi, Chennai-62.

## Abstract:

*Indian Railways is one of the world's largest railway networks in the world, transporting over 18 million passengers and more than 2 million tonnes of freight daily. Hence, the security of Indian railways becomes indispensable. The illegal removal of fish plates and collision on the same track leads to crash. The objective of our paper is to develop a radical system for continuous monitor of fish plates using power relays and immediate signalling on said fish plates removal. In our proposed system we record the trains on the same track using the GPS module. GPS module interfaced with an ARDUINO board reads the geographical coordinates of the train's position so that the trains can be halted by applying emergency brakes and sending signals to both the train brake and train control rooms. Should such a case occur the train starts applying the brakes at a distance of 1 Km from the incident location? It is expected that if this system is implemented widely, train collisions and accidents can be avoided and amount of losses could be negated.*

**Keywords:** Power relays, GPS module, ARDUINO Board.

## INTRODUCTION:

Transport is very important to carry the passengers and goods from one place to another. Better transport leads to increased rate of trade. Economic level is highly dependent on increasing the capacity and quality of transport. In recent years, many passenger and goods train have derailed or suffered from collisions due to damages in rails. The damages to tracks are predominantly due to missing fish plate's accounts for the maximum number of such cases. People illegally remove fish plates for monetary benefits. Various terrorist outfits have also been involved in such detrimental activities. In other cases trains collide each other and leading to huge loss of life and trade goods.

### Head-On & Rear-End Collisions:

A head-on collision is one where the front ends of two vehicles hit each other, as opposed to a side-collision or rear-end collision. With rail, a head-on collision often implies a collision on a single line railway. In this paper we concentrate on detection of fish plate removal and collision of trains on same track using power relays, ARDUINO board and GPS sensor.

## EXISTING SYSTEM:

The existing system uses sensors and GSM technology that provide security and collision avoidance. This system has been designed and simulated using a real time simulation software. Various models for the railway traffic systems has also been generated and tested. Various sub modules communicate with each other and with a central monitoring station where entire data is stored and monitored.

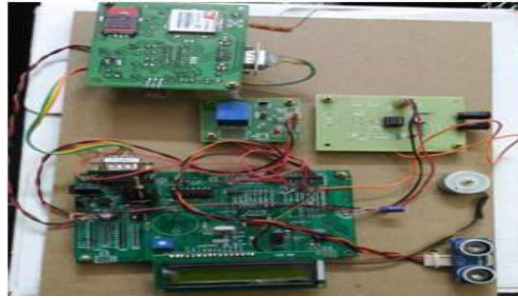

## PROPOSED SYSTEM:

The proposed train anti-collision system consists of detection of missing fish plates and/or cracks occurring in the tracks using power relays. Signal produced by power relays is sensed by the Arduino board and halts the train automatically as per the program that has been pre-programmed on said board. GPS sensor is also proposed in this system in order to locate the trains on the same track which is interfaced with the Arduino board in order to avoid any collisions that may occur.

## POWER RELAY:

A power relay is a switch which is used to open or close a circuit using electromagnetic coils. Power relays also contain an armature, a spring and one or several contacts. If the power relay is normally designed to be open, when power is supplied, the electromagnet attracts the armature, which is then pulled in the coil's direction until it reaches a contact, therefore closing the circuit. If the relay is normally designed to be closed, the electromagnetic coil pulls the armature away from the contact, therefore opening the circuit.

Power relays are used for many different applications, including:

- Automotive electronics
- Audio amplification
- Telephone systems
- Home appliances
- Vending machines
- Etc.



In our paper we use power relays for supply of low voltage high ampere current (which is equivalent to range of the battery) to the tracks to detect the removal of fish plates or any cracks leading to the emergency braking protocol being executed.

## ARDUINO BOARD:

Arduino is hardware or software microcomputer project, and user community that are used to design and manufacture microcontroller kits for developing digital devices and interactive objects that can sense and control objects in the real world. The project's products are distributed as open source hardware and software, which are licensed under the GNU Lesser General Public License (LGPL) or the GNU General Public License (GPL), allowing the producer of Arduino boards and software distribution by anyone. These systems provide sets of digital and analog input/output (I/O) pins that may be interfaced to various expansion boards or shields and other circuits. The board's features serial communications interfaces, including Universal Serial Bus (USB) on some models, for loading programs from personal computers. The microcontrollers are mainly programmed using a dialect (local parlance) of features from the programming languages of C and C++. In addition to using traditional compiler tool chains, the Arduino project provides an integrated development environment (IDE) based on the Processing language project. Christo Ananth et al. [4] discussed about an eye blinking sensor. Nowadays heart attack patients are increasing day by day. "Though it is tough to save the heart attack patients, we can increase the statistics of saving the life of patients & the life of others whom they are responsible for. The main design of this project is to track the heart attack of patients who are suffering from any attacks during driving and send them a medical need & thereby to stop the vehicle to ensure that the persons along them are safe from accident. Here, an eye blinking sensor is used to sense the blinking of the eye. SpO2 sensor checks the pulse rate of the patient. Both are connected to micro controller. If eye blinking gets stopped then the signal is sent to the controller to make an alarm through the buffer. If spO2 sensor senses a variation in pulse or low oxygen content in blood, it may result in heart failure and therefore the controller stops the motor of the vehicle. Then Tarang F4 transmitter is used to send the vehicle number & the mobile number of the patient to a nearest medical station within 25 km for medical aid. The pulse rate monitored via LCD. The Tarang F4 receiver receives the signal and passes through controller and the number gets displayed in the LCD screen and an alarm is produced through a buzzer as soon the signal is received.

There is an onboard micro-SD card slot, which can be used to store files for serving over the network. The on board micro-SD card slot is compatible with all the Arduino/Genuine boards. The on-board micro SD card reader is accessible through the SD Library. The working with this library, SS is on Pin 4. The original revision of the shield contained a full-sized SD card slot; this card slot is not supported. The shield also includes a reset controller. This is to ensure that the W5100 Ethernet module is properly reset on power-up. Previous revisions of the shield were not compatible with the Mega and hence need to be manually reset after power-up. Christo Ananth et al. [5] discussed about a system, GSM based AMR has low infrastructure cost and it reduces man power. The system is fully automatic, hence the probability of error is reduced. The data is highly secured and it not only solve the problem of traditional meter reading system but also provides additional features such as power disconnection, reconnection and the concept of power management. The database stores the current month and also all the previous month data for the future use. Hence the system saves a lot amount of time and energy. Due to the power fluctuations, there might be a damage in the home appliances. Hence to avoid such damages and to protect the appliances, the voltage controlling method can be implemented.

## ARDUINO ETHERNET SHEILD II

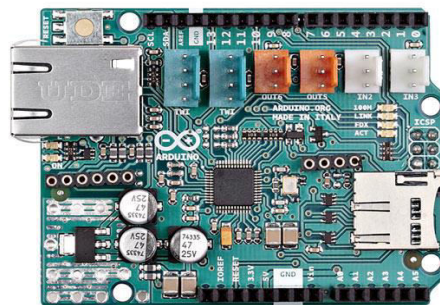

## GPS MODULE:

Global Positioning System (GPS) sensors are receivers with antennas that use a satellite-based navigation system with a network of 24 satellites in orbit around the earth to provide position, velocity, and timing information. Receiver position is calculated from the position of satellites and the distances to them. Distance is calculated from the time a radio signal travels between satellite and receiver. Indian Railways have made an announcement that the trains may soon get real-time GPS tracking system to avoid accidents. According to these sources, the real time GPS tracking system will be integrated with Google Maps so that it will be accessible through range of mobile devices & computers.

The technology arm of the Indian Railways, the Centre for Railway Information Systems (CRIS), has developed a GPS-based solution with help of Indian Space Research Organization (ISRO), which can provide exact location of a train with an accuracy of 10 metres, and latency of 2 minutes, on a real-time basis. As per reports, the price of GPS devices will be approximately Rs 75,000 – 1,00,000 per train, would be fitted in about 100 trains, which may help avert collisions and avoid loss of lives. In effect, trains in future will be aware of each other's location, and start breaking, in case of danger ahead.



## INTEGRATION OF POWER RELAYS AND ARDUINO BOARD:

Power relay supply low volt high ampere current (which is same as range of battery) through tracks. If any removal of fish plates or cracks occurs the signal passing through the tracks gets halted. In that case power relay gets a message that no more signals are passing further. Then Arduino board which is fitted in the control room of the each train, receive signals from the power relays and halt the train according to the program that has been designed in the board.

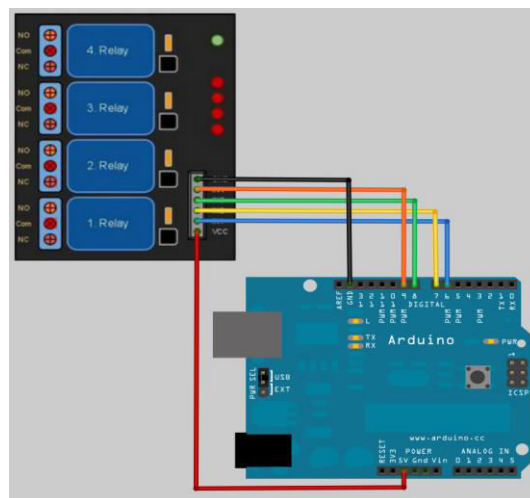

## GPS WITH ARDUINO:

The GPS navigates the direction of each train, and sense the location of surrounding train. If the two trains travel on same meridians (same longitudinal and latitudinal direction) collisions may occur. To prevent such cases the GPS senses and pass the information to the Arduino board interfaced with it. A program is pre-programmed in the Arduino board which neither makes the train choose another path nor halt the train.

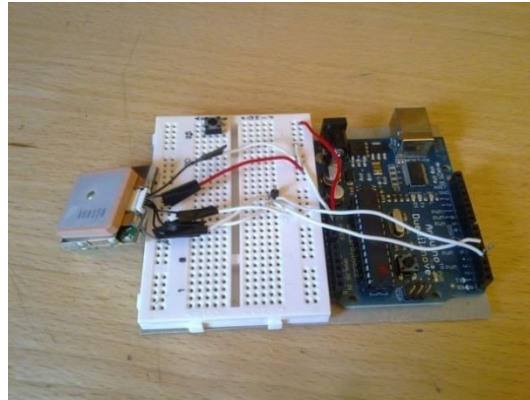

## EXAMPLE OF PROGRAM DESIGNED FOR GPS INTERFACED ARDUINO

```
COM13
Send
$GPRMC,1.1,03.17,A,38.12,S,34.05,E,49.7B
$GPRMC,235950.968,V,0.00,0.00,050180,,N*4E
$GPGGA,235951.968,0.0,M,0.0,M,0.0,0000.0
$GPRMC,1.1,04.17,A,38.12,S,33.05,E,49.02,,34*7E
$GPRMC,235951.968,V,0.00,0.00,050180,,N*4F
$GPGGA,181834.103,0.0,M,0.0,M,0.0,0000.0
$GPRMC,2.1,05.17,A,38.12,S,33.24,S,35.05,,49*79
$GPRMC,181834.103,V,0.00,0.00,110180,,N*41
$GPGGA,181835.103,0.0,M,0.0,M,0.0,0000.0
$GPRMC,2.1,05.17,A,38.12,S,33.24,S,36.05,,49*7A
$GPRMC,181835.103,V,0.00,0.00,110180,,N*40
$GPGGA,181836.103,0.0,M,0.0,M,0.0,0000.0
$GPRMC,2.1,05.17,A,38.12,S,33.24,S,36.05,,49*7A
$GPRMC,181836.103,V,0.00,0.00,110180,,N*43
$GPGGA,181837.103,0.0,M,0.0,M,0.0,0000.0
Autoscroll Both NL & CR 9600 baud
```

## FUTURE ENHANCEMENT

The Paper has a very vast scope in future. The proposed system can be further upgraded in future to make a centralised control system for all trains. Prediction algorithm can also be launched in the system to prevent collisions.

## CONCLUSION

The main intension of the project is to prevent train collisions. By using this project many human lives can be saved. This project can work in any atmospheric conditions. Without any human involvement the trains will automatically stops. Through this innovative technique of early sensing of any possible collision scenario and avoiding it thereof, we demonstrate that it is a

possible way to improve the overall safety of the railway system in India. We believe that success depends on both the railway industry.

## REFERENCES

- [1] Wheeler, "Commercial Applications of Wireless Sensor Networks using ZigBee", IEEE Communications Magazine, April 2007.
- [2] [http://www.ikalogic.com/ir\\_prox\\_sensors.php](http://www.ikalogic.com/ir_prox_sensors.php)
- [3] SomprakashBandhopadhyay, Pradeep Ghosh, Anural D ,'GPS based Vehicular Collision Warning System using IEEE 802.15.4 MAC/PHY Standard'.B
- [4] Christo Ananth, S.Shafiqa Shalaysha, M.Vaishnavi, J.Sasi Rabiya Sabena, A.P.L.Sangeetha, M.Santhi, "Realtime Monitoring Of Cardiac Patients At Distance Using Tarang Communication", International Journal of Innovative Research in Engineering & Science (IJIRES), Volume 9, Issue 3,September 2014,pp-15-20
- [5] Christo Ananth, G.Poncelina, M.Poolammal, S.Priyanka, M.Rakshana, Praghash.K. "GSM Based AMR", International Journal of Advanced Research in Biology, Ecology, Science and Technology (IJARBEST), Volume 1,Issue 4,July 2015, pp:26-28 [6]K. Vijayakumar, S.R. Wylie, J.
- [6] D. Cullen, C.C. Wright, and A.I. AlShamma'a, "Noninvasive rail track detection system using Microwave sensor", Journal of App. Phi., 2009.
- [7] M.Cacciola, G. Megalith, D. Pelican, Calcagno, M. Versace, and F. C. Moabite, "Rotating Electromagnetic Field for Crack Detection in Railway Tracks", PIERS ONLINE, Vol. 6, NO. 3, 2010
- [8] Wojnarowski, Robert John Welles, Kenneth BrakeleyKornrumpf, and William Paul, "Electromagnetic system for railroad track crack detection and traction enhancement
- [9] T.Dhanabalu, S.Sugumar, S.Suryaprakash, A.VijayAnand "Sensor based identification system for Train Collision Avoidance", in IEEE Sponsored 2nd International Conference on Innovations in Information Embedded and Communication Systems,2015,p.no.1-2.
- [10] S.Gautam, S.Nemade, T.Sakla "Simulation of an anti-collision system on same track for railways", in International Journal of Engineering and Technology, Vol. 2(9), 2010, pp.4832-4837.
- [11] Arup, Sarthe. S, KM.Martin, Madhukumar.S "an efficient train anti-collision system using LEO two way satellite communication". "A concept for reducing railway accidents", H Ben Brown, Jr. Gregg Ponder, Mel Siegel, February, 2005.