

Hydro-Solar Hybrid Power Generation with Battery Energy Storage System (BESS)

Milton.C

Assistant professor, Department of EEE, James college of Engineering and Technology.

ABSTRACT:

In this thesis hybrid of Hydro-Solar generation system employing one Permanent Magnet Synchronous Generator (PMSG) driven by a constant-power hydro turbine. It works as an uninterruptible power source that is able to feed a certain minimum amount of power into the load under all conditions. Power transfer was different modes of operation, including normal operation without use of battery, which gives the user-friendly operation. A control strategy regulates power generation of the individual components so as to give the hybrid system to operate in the proposed modes of operation. The concept and principle of the hybrid system and its control were described. The proposed system using PMSGs and a voltage and frequency controller are modeled and simulated in MATLAB using Simulink and Sim Power System set toolboxes, and different aspects of the proposed system are studied for various types of linear and nonlinear loads under varying conditions. The performance of the proposed system is presented to demonstrate its Voltage and Frequency Control (VFC), harmonic elimination, and load balancing.

Key Words: Uninterrupted Power Supply, Elimination of harmonics, using of Renewable Energy Source, balancing of load demand.

I. INTRODUCTION:

The Solar, Hydro, Wind and Biomass are the renewable energy sources. RES is derived from natural processes that are replenished constantly such as sunlight, water, wind, tides, plant growth and geothermal heat. Solar energy can be

produced from the radiation that rises from the sunlight. The total solar irradiance is defined as the amount of radiation energy emitted by the sun over all wavelengths, not just visible light, falling each second on a one square meter perpendicular plane outside earth atmosphere at a given distance from the sun. It is roughly constant, fluctuation by only a few parts per thousand from day to day. On the outer surface of the earth's atmosphere the irradiation is known as the solar constant and is equal to about 1367watts per square meter. The amount of solar energy that actually passes through the atmosphere and strikes a given area on the earth over a specific time varies with latitude and with the season as well as weather and is known as the insolation. When sun is directly overhead the insolation, that is the incident energy arriving on a surface on the ground perpendicular to the sun's rays, is typically 1000watts per square meter. This is due to the absorption of the sun's energy by the earth's atmosphere which dissipates about 25% to 30% of the radiation energy.

Hydro-power or water power is power derived from the energy of falling water and running water, which may be harnessed for useful purpose. The power available from falling water can be calculated from the flow rate and density of water, the height of fall and the local acceleration due to gravity. In SI units, the power is

$$P = \eta\rho Qgh$$

Where P is the power in watts, η is the dimensionless efficiency of the turbine, ρ is the density of water in kilograms per cubic meter, Q is the flow in cubic meter per

second, g is the acceleration due to gravity, h is the height difference between inlet and outlet. The force of water will rotate the

blades of the turbine by which the generator starts to produce electrical supply.

HYDRO SYSTEM

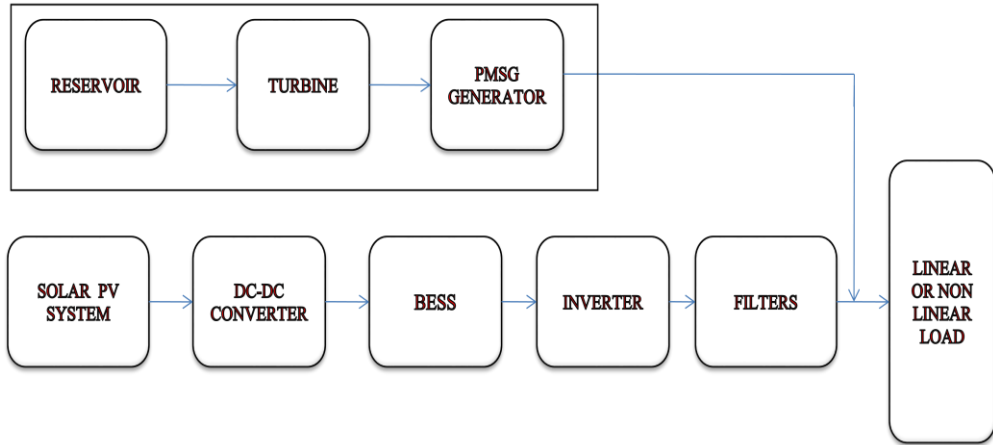

Block Diagram

Above Block Diagram shows the hybrid of hydro and solar with battery energy storage system. Hydro system contains Reservoir, Turbine and PMSG Generator and the Solar System consist of photovoltaic panels, Dc-Dc converter, Battery Storage system and Inverter with filter. The combination hydro and solar system will be given to the linear or non-linear loads.

The rest of this paper organized as follows, the principle of operation of the proposed hybrid system is given in II. In Section III, a design procedure is presented for selection of various components of the proposed system. In Section IV, the developed MATLAB-based simulation is discussed for the proposed system. In Section V, the simulation results for the proposed system under linear load, nonlinear load presented and discussed verifying the validity of the proposed system.

II. PRINCIPLE OF OPERATION:

Proposed system is the hybrid of hydro and solar to supply regular power to the load without interruption. Source energy of the Hydro is water and the source energy of the solar system is sun. Hydro system use running water to generate electricity, whether it's a small stream or a large river. Small or micro hydroelectricity systems also called as hydropower, which can produce enough electricity for lighting and electrical appliances in an average home. The streams and rivers flow downhill. Before the water flows down the hill, it has potential energy because of its height. Hydro power systems convert this potential energy into kinetic energy in the turbine, which drives a PMSG generator to produce electricity. The greater the height and the more water there is flowing through the turbine the more electricity can be generated.

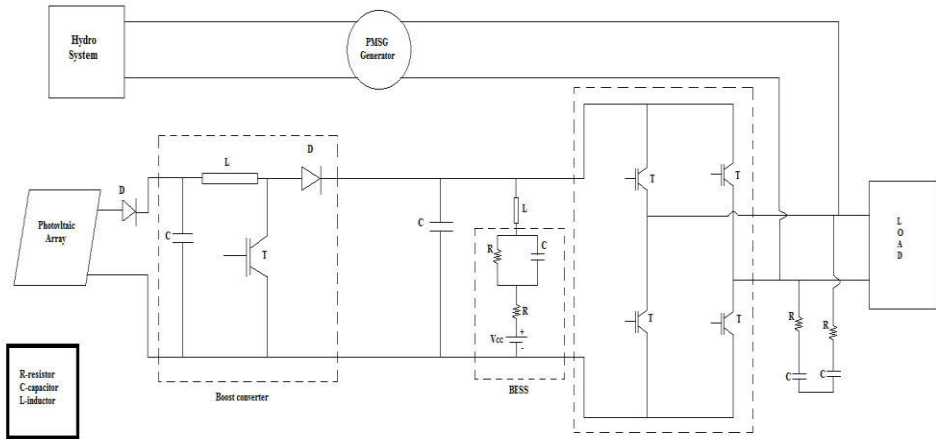

Schematic diagram of HYDRO-SOLAR HYBRID SYSTEM

Hydro system can be divided as small hydro, Micro hydro and pico hydro. Small hydro is the development of hydroelectric power on a scale serving a small community or industrial plant. The capacity of the small hydro system is 10Mw. Micro hydro is a term used for hydroelectric power installations that typically produce up to 100Kw of power. Picro hydro is a term used for hydroelectric power generation of under 5Kw. This system combined with Solar system, which has photovoltaic panels with Battery connected inverter. Solar system made up of PV panels which will produce power from the sunlight. Boost converters are used for step up the voltage profile and the inverter is used to convert the direct current into alternating current.

The above Schematic diagram shows the Hydro-Solar hybrid system. Hydro turbine used to convert the pressure of the water into mechanical energy. Mechanical energy converted into electrical energy by use of PMSG and given to load. The outcome of DC supply from PV given to boost converter, which will step up the voltage and remove the

voltage ripples. The DC supply from PV system was inserted to BESS. From the BESS, power flow to inverter which convert the DC supply into AC and given to load side or grid.

III. DESIGN OF PROPOSED SYSTEM:

The following subsections describe the procedure for selection of ratings for battery capacity, Boost Converter, permanent magnet synchronous generator and Inverter.

A. Selection of Battery Design:

The dc-bus voltage (V_{dc}) must be more than the peak of the line voltage for satisfactory PWM control,

$$V_{dc} > 2 (2/3) V_{ac} \text{ ma}$$

Where ma is the modulation index normally with a maximum value of one and V_{ac} is the rms value of the line voltage on the ac side of the inverter. The maximum rms value of the line voltage at converter terminals as well as the rms value of the line voltage at the load terminals is 415 V. V_{dc} should be more than 677.7 V. The voltage of the dc link and the battery bank is selected as 700 V. Considering the ability of the proposed system to supply electricity to a load of 60 kW for 10 h, the design storage capacity of the battery

bank is taken as 600 kW · h. The commercially available battery bank consists of cells of 12 V. The nominal capacity of each cell is taken as 150 Ah. To achieve a dc-bus voltage of 700 V through series connected cells of 12 V, the battery bank should have $(700/12) = 59$ number of cells in series. Since the storage capacity of this combination is 150 A · h, and the total ampere hour required is $(600 \text{ kW} \cdot \text{h}/700 \text{ V}) = 857 \text{ A} \cdot \text{h}$, the number of such sets required to be connected in parallel would be $(857 \text{ A} \cdot \text{h}/150 \text{ A} \cdot \text{h}) = 5.71$ or 6 (selected). Thus, the battery bank consists of six parallel-connected sets of 59 series-connected battery cells. Thevenin's model is used to describe the energy storage of the battery in which the parallel combination of capacitance and resistance in series with internal resistance and an ideal voltage source of voltage 700 V are used for modeling the battery in which the equivalent capacitance.

B. Permanent magnet synchronous generator:

Power flow provide by the machine is calculated by

$$2Q_s = V_c / (2\pi f L)$$

Where V_c is the maximum line voltage generated and f is the frequency. Frequency can be calculated by

$$f(\text{Hz}) = \text{RPM} \frac{P}{120}$$

The PMSG differs from the Induction Generator in that the magnetization is provided by a Permanent Magnet Pole System on the rotor, instead of taking excitation current from the armature winding terminals, as it is the case with the Induction Generator. This means that the mode of operation is synchronous, as opposed to asynchronous. That is to say, in the PMSG, the output frequency bears a fixed relationship to the shaft speed, whereas in the mains connected IG, the frequency is closely related to the network frequency, being related by the slip. These differences will be discussed at length. However, it must be recognized at the outset that the differences have a significant effect on the operating characteristics and performance of the two generator types.

Permanent magnet Synchronous machines may be set in several categories, those with surface mounted magnets, those with buried magnets, those with damper windings, etc., etc. All categories where data was found were considered, as each has some special features to offer. The advantages of PM machines over electrically excited machines can be summarized as follows according to literatures:

- Higher efficiency and energy yield,
- No additional power supply for the magnet field Excitation,
- Improvement in the thermal characteristics of the PM machine due to the absence of the field losses,
- Higher reliability due to the absence of Mechanical components such as slip rings,
- Lighter and therefore higher power to weight Ratio.

In recent years, the use of PMSG is more attractive than before, because the performance of PMSG is improving and the cost of PMSG is decreasing. The trends make PMSG machines with a full-scale power converter more attractive for direct-drive wind turbines. Considering the performance of PMSG is improving and the cost of PMSG is decreasing in recent years, in addition to that the cost of power electronics is decreasing, variable speed direct-drive PMSG machines with a full-scale power converter become more attractive for hydro powers.

C. Boost Converter:

A boost converter (step-up converter) is a DC-to-DC power converter with an output voltage greater than its input voltage. It is a class of switched-mode power supply (SMPS) containing at least two semiconductor switches (a diode and a transistor) and at least one energy storage element, a capacitor, inductor, or the two in combination. Filters made of capacitors (sometimes in combination with inductors) are normally added to the output of the converter to reduce output voltage ripple. Power for the boost converter can come from any suitable DC sources, such as batteries,

solar panels, rectifiers and DC generators. A process that changes one DC voltage to a different DC voltage is called DC to DC conversion. A boost converter is a DC to DC converter with an output voltage greater than the source voltage. A boost converter is sometimes called a step-up converter since it “steps up” the source voltage. Since power ($P=VI$) must be conserved, the output current is lower than the source current. The duty cycle for the converter can be calculated from the formula.

$$D=1-\frac{V_{in}}{V_{out}}$$

Also the frequency should be in the limit

$$\frac{4(1-D_{max})}{3(T_r+T_f)+4T_{off}} \leq f \leq \frac{4D_{min}}{T_r+T_f+4t_{on}}$$

D. Inverter:

A power inverter, or inverter, is an electronic device or circuitry that changes direct current (DC) to alternating current (AC). The input voltage, output voltage and frequency, and overall power handling, are dependent on the design of the specific device or circuitry. A power inverter can be entirely electronic or may be a combination of mechanical effects (such as a rotary apparatus) and electronic circuitry. Static inverters do not use moving parts in the conversion process.

Typical applications for power inverters include:

Portable consumer devices that allow the user to connect a battery, or set of batteries, to the device to produce AC power to run various electrical items such as lights, televisions, kitchen appliances, and power tools. Use in power generation systems such as electric utility companies or solar generating systems to convert DC power to AC power. Use within any larger electronic system where engineering need exists for deriving an AC source from a DC source.

A typical power inverter device or circuit will require a relatively stable DC power source capable of supplying enough current for the intended overall power

handling of the inverter. Possible DC power sources include: rechargeable batteries, DC power supplies operating off of the power company line, and solar cells. The inverter does not produce any power, the power is provided by the DC source. The inverter translates the form of the power from direct current to an alternating current waveform. The level of the needed input voltage depends entirely on the design and purpose of the inverter. In many smaller consumer and commercial inverters a 12V DC input is popular because of the wide availability of powerful rechargeable 12V lead acid batteries which can be used as the DC power source. An inverter can produce square wave, modified sine wave, pulsed sine wave, or sine wave depending on circuit design. The two dominant commercialized waveform types of inverters are modified sine wave and sine wave. There are two basic designs for producing household plug-in voltage from a lower-voltage DC source, the first of which uses a switching boost converter to produce a higher-voltage DC and then converts to AC. The second method converts DC to AC at battery level and uses a line-frequency transformer to create the output voltage.

IV. MATLAB BASED MODELING:

A simulation model is developed in MATLAB using Simulink and Sim Power System set toolboxes. The simulation is carried out on MATLAB version 7.12. The electrical system is simulated using Sim Power System. The developed MATLAB 2011 model for the hydro-Solar hybrid system is shown in Figure.

V. RESULTS AND DISCUSSIONS:

The proposed Hydro-solar hybrid power generation with battery energy storage system is shown in the figure.

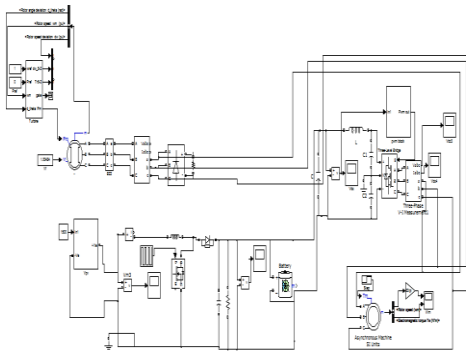

Fig 1. Test system of hydro-solar hybrid system

Fig1 shows the simulated diagram of proposed system. The voltage profile of the outcome of PV panel, Boost converter and three phase output of PMSG where shown below.

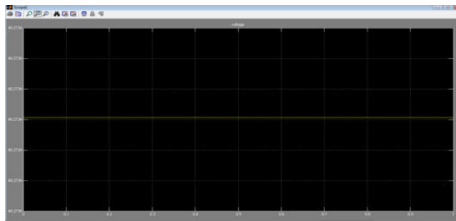

Fig 2. PV Panel output Voltage

This is the waveform of output voltage of PV panel, which was given to the Boost Converter to step up the Voltage.

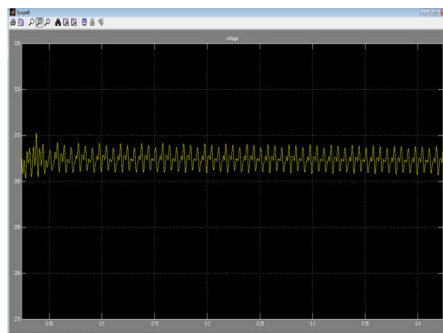

Fig 3. Boosted voltage from Boost Converter

It shows the voltage waveform of Boost Converter, where the PV panel voltage of 40V was step up to above 300V to store the charge in the Battery energy storage system.

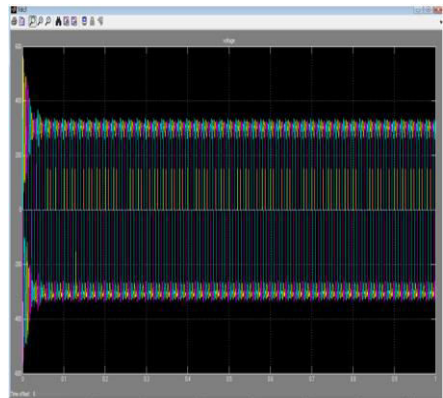

Fig 4. Three phase output from hydro and Solar

The inverted Voltage of Battery Energy Storage System and the output supply from the PMSG to three phase load system were shown above.

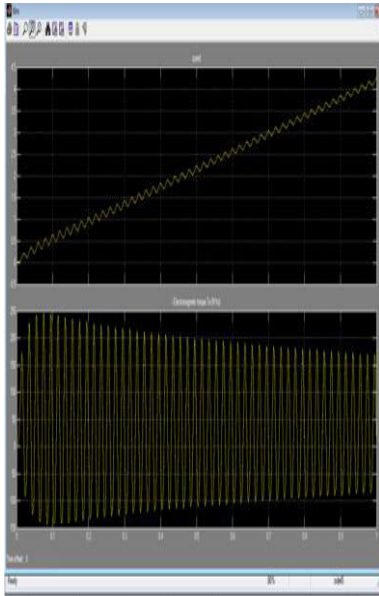

Fig 5.Speed and the Torque of Asynchronous machine which was assumed as load in the proposed system

In this proposed system the supply can be transferred to load or grid, but here asynchronous machine is assumed as load. The output power from the hybrid of solar and the hydro were given to the asynchronous motor. Hydro system and the solar system can be supply the power to the load simultaneously or separately. If the outcome of both the system becomes zero then the stored energy from the Battery Energy Storage System will be utilized.

VI. CONCLUSION:

As the fossil fuels goes on decreasing the power can be generated from Renewable Energy Source is essential one. In this system both the Solar and hydro are hybrid to generate power for the load side or grid. The generated power of Solar is stored in the Battery Energy Storage system; the stored energy will be utilized when the output of both hydro and solar is zero. Proposed system

of Hydro-Solar Hybrid power generation with Battery Energy Storage System were designed and implemented in MATLAB using Simulink and Sim Power System tool boxes.

Reference:

- [1] Alejandro Rolan, Alvaro Luna, Gerardo Vazquez, and Daniel Aguilar. (2009) 'Modelling of a Variable Speed Wind Turbine with a Permanent Magnet Synchronous Generator', IEEE International Symposium on Industrial Electronics Seoul Olympic Parktel, Seoul, Korea, Vol. 6, No.4, pp. 434-442.
- [2] Castronuovo, E.D. and Pecas, J. A. (2004) 'Bounding Active Power Generation of a Wind-Hydro Power Plant', in Proceeding, 8th Conference, Probabilistic Methods Application, Power System, AMES, IA, Vol.7, No.8, pp. 705-710.
- [3] Murthy, S. S. Singh, B. Goel, P. K. and Tiwari, S. K. (2007) 'A Comparative Study of Fixed Speed and Variable Speed Wind Energy Conversion Systems Feeding the Grid', in Proceeding, IEEE PEDS, Vol.13, No.5, pp. 736-743.
- [4] Rajveer Mittal, Sandu, K.S. and Jain, D.K. (2009) 'Isolated Operation of Variable Speed Driven PMSG for Wind Energy Conversion System', IACSIT International Journal of Engineering and Technology Vol. 1, No.3, ISSN: 1793-8236.
- [5] Singh, B. and Kasal, G. K. (2008) 'Voltage and Frequency Controller for a Three-Phase Four-Wire Autonomous Wind Energy Conversion System', IEEE Transaction Energy Conversion., Vol. 23, No. 2, pp. 505-518.
- [6] Tamas.L and Szekely,Z. (2008) 'Modeling and Simulation of an Induction Drive with Application to a Small Wind Turbine Generator', in Proceeding. IEEE International Conference. Automobile Quality Test. Robot, May 22-25, pp. 429-433.

[7] Yang, T.C. (2008) 'Initial Study of using Rechargeable Batteries in Wind Power Generation with Variable Speed Induction Generators', IET Renewable Power Generation., Vol. 2, No. 2, pp. 89–101.

[8] "Standalone wind-hydro hybrid generation system with dump power control and battery energy storage system(BESS)" IJERT, ISSN:2278-0181, vol.2 issue 1, jan 2013.

[9] "Battery energy storage station based smoothing control of pv and wind power generation fluctuations" IEEE, vol 4, no2, April 2013.

[10] "Hybrid wind-solar energy system: anew rectifier stage topology" IEEE 2010.

[11] "Variable speed of the wind turbine generation with DFIG connected to electric grid" Vol 11 N3(2008).