

Long leads for submersible pumps using PWM inverter fed induction motor

M.B.RATHNAPRIYA¹

PG scholar, Department of EEE
Sona College of Technology
Salem, Tamilnadu, India

A.JAGADEESHWARAN²

Associate Professor, Department of EEE
Sona College of Technology
Salem, Tamilnadu, India

Abstract—This project aims to study the effect of long leads on PWM inverter fed induction motor. In many applications, the PWM inverter and motor must be at separate locations. Therefore, the motor and drive are connected using long cable. Analysis is presented to show that the distributed LC of the cable and the pulse width modulated (PWM) inverter switching action. Further, long cable lengths contribute to a damped high frequency ringing at the motor terminals due to the distributed nature of the (LC) which result in overvoltages and further cause stresses in the motor insulation. Therefore, overvoltage occurs at the motor terminals. Thus, a filter is required to reduce the overvoltage at the motor terminals. Simulation results are presented to verify the proposed filter designs for long cable lengths for 460-V PWM insulated gate bipolar transistor (IGBT) motor drive systems.

Keywords—Overvoltage, Pulse width modulation, inverter, Filter circuit, induction motor, motor lead.

I. INTRODUCTION

Advances in power electronic devices for switching operation such as IGBT's, etc has improved the performance of PWM inverter and has enabled high frequency switching operation. In many applications, the rectifier and PWM inverter of high frequency, controls both the frequency and voltage supplied to the motor, and it achieves the variable speed operation.

The long cable is employed in many applications such as submersible pump drive system and retrofit industrial applications. Further, the motor and PWM inverter must be at separate locations, thus needs long cable. Zero switching losses and high switching speeds significantly increases the operation of PWM inverters. Therefore, the long cable lengths contribute to a damped high frequency ringing at the motor terminals. Thus, results in excessive overvoltage, due to the distributed nature of LC(leakage inductance and coupling capacitance), which causes stress in motor insulation.

Steep voltage pulse rise time causes overvoltage problems, which is an important research area during the last decade. The traveling-wave and reflection phenomena describes the overvoltage phenomena. At the inverter, a voltage pulse is initiated, which is being reflected at the motor terminals due to the mismatch of input impedance of motor and characteristic impedance of the cable. The overvoltage magnitude depends upon the characteristics , pulse rise time and cable length [1-2].

Filtering techniques are analyzed to reduce the adverse effects of long motor leads on ac motor drive systems, where the ringing, dv/dt, overvoltage phenomenon are studied clearly using voltage reflection theory [3-4]. Simple damping circuits such as series C-R circuit and parallel L-R circuit suppress the overvoltage and ringing at the motor terminal [5]. Filter at the inverter output reduces the motor overvoltage from ASD's to ac drive , where long cables are required [4]. The filter output was compared with the shunt filter of motor terminals was designed to reduce the ringing and overvoltage [3-5].

Transmission theory of cable, voltage reflections and cable capacitance analysis are studied [6]. Overvoltages are analyzed and filter resistance is selected to match the characteristic impedance of cable and motor [7]. Here, the filter capacitance is chosen in order to reduce the voltage stress of motor.

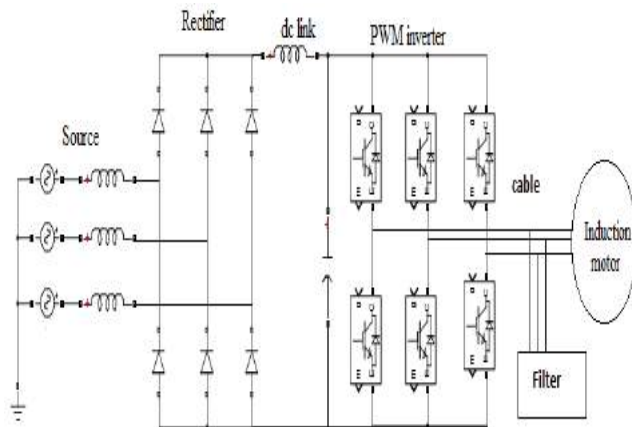

Fig.1 PWM inverter driving an induction motor with filter at the end of the cable.

The motivation of work presented in this project is of simulation results, which helps to investigate accurately about the phenomena of overvoltage. The main goal of this paper is to study the overvoltage phenomena of motor in a definitive manner and thereby demonstrating the filter at the motor terminals by developing accurate and fast simulation models for motor and long cables.

This paper investigates the overvoltage phenomena and the filter is employed at the end of the cable to reduce the overvoltage and stress at the motor insulation, see Fig.1.

For this type of application such as submersible pump and retrofit the cable needed must be durable and reliable. An accurate simulation model is developed for long motor leads using PWM inverter and the results are shown for the induction motor drive.

II. PROBLEMS IN VFD AND CABLE

Variable Frequency Drive (VFD) are employed in compressors and mill drives. On VFD side, there is a problem on switching frequency increases. By using filter at the converter output, which can lead to high pulses of current at the inverter side.

Overvoltage occurs at the motor terminals due to the voltage reflection of pulses. On long cables, the combination of impedance of cable, input impedance of motor and switching frequency of VFD that reflects the voltage into the motor terminals. This overvoltage takes place due to increasing in switching frequency, thereby time interval between the voltage pulses will be lower. Thus, the voltage pulse travelling to the motor will combine to the pulse which is being reflected. Therefore "double pulsing" results in excessive overvoltage, which causes stress in the motor insulation.

III. LONG MOTOR LEAD ON INDUCTION MOTOR

In this paper, induction motor is chosen for submersible pumps.

Three-phase induction motor driving an submersible pump is widely used in many industrial areas playing a major role. It is easier to develop a model for an induction motor driven submersible pump using this package, as many of the components are included in the SIMULINK block library. This makes simulation design easier. It is easy to capture, store, process and display the results using predefined functions for these purposes.

Long cable lengths contribute to a damped high frequency ringing at the motor terminals resulting in over Voltages which further stress the motor insulation. If a long cable is employed between the inverter and the motor, damped high frequency ringing at the motor terminals occurs resulting in excessive overvoltage which further stresses the motor insulation.

Also, the motor impedance, which is dominated by the winding inductance, presents an effective open circuit at high frequencies at the end of the long cable. This produces a reflected voltage at the end of the cable approximately equal in magnitude and with the same sign, resulting in twice the magnitude of the incident voltage at the motor terminals.

A. Advantages of induction motor

- Induction motor can operate in wide range of industrial conditions.
- They are sturdy and robust.
- It is cheaper in cost.
- The construction of IM is simple.
- It does not have accessories such as slip rings or commutator and brushes.
- Less maintenance.
- No need for an complex circuit for starting.
- The three motor is self starting. Whereas, the single phase motor can be self-starting, by connecting a capacitor in the auxiliary winding.
- Dc motors produce sparks, whereas the IM does not produce any sparks.
- The IM can be operated under water and also in hazardous environments.

B. Voltage reflection analysis

PWM pulses behaves like traveling waves, while traveling between the inverter on transmission lines in long cables. PWM pulses or forward-traveling waves, moving from the inverter to the motor. whereas, backward-traveling waves travel toward the inverter from motor due to voltage rejection. The reflection mechanism can be viewed as a mirror that produces a reflected wave V^- which is a replica of V^+ that is “flipped around” such that all points on the V^- waveform are the corresponding points of the V^+ waveform multiplied by the voltage rejection coefficient.

The reflections of voltage during incident wave under three extreme conditions are stated below:

- At the end of the cable, the voltage reflected at the cable end will be equal in magnitude but resulting in zero voltage with a negative sign at the motor terminals.
- At the end of the cable is open, the voltage reflected at the cable end will be equal in magnitude without changing the sign (i.e.) same in sign, resulting in two times the magnitude of the incident voltage at the motor terminals.
- If the cable is terminated by an impedance that matches the characteristic impedance of the cable, the incident voltage will not be reflected, but a refraction voltage equal to the incident voltage will result. 2.0 ps.

The impedance of smaller motors is dominated by the winding inductance, thus in comparison to the low surge impedance of the cable, the motor impedance is high and is equivalent to an open circuit at high frequencies. The load and source reflection coefficients, Γ_L and Γ_s respectively, can be expressed as,

$$\Gamma_L = \frac{R_L - R_c}{R_L + R_c} \tag{1}$$

where R_L is the load resistance and R_c is the characteristic resistance (or surge impedance) given by,

$$R_c = \sqrt{\frac{L_c}{C_c}} = Z_{0c} \tag{2}$$

where L and C , are cable parameters. Then the source voltage reflection coefficient is defined as,

$$\Gamma_s = \frac{R_s - R_c}{R_s + R_c} \tag{3}$$

where R_s is the source resistance. At the inverter, the reflected forward-traveling wave has the same shape as the incoming backward-traveling wave but with corresponding points reduced by Γ_s .

Since after two transitions of the cable, the resulting reflected wave will be negative, the peak motor terminal voltage can be found by determining the total voltage due to reflections after three transitions of the cable, and adding this to the incident wave voltage magnitude.

IV. FILTER DESIGN

The fig.2 shows the voltage at the end of the cable. Thus, it clearly shows that the overvoltage takes place at the end of the cable without using filter.

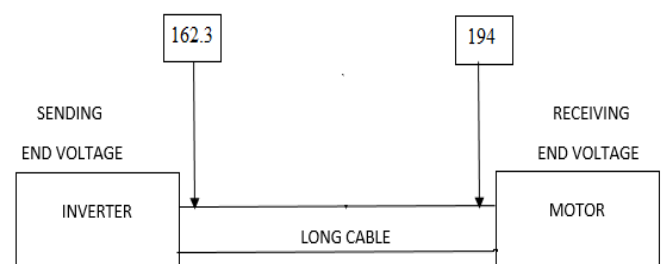

Fig.2. voltage of the cable without filter

Thereby, RCL filter is used, in which the resistance of filter matched with the characteristic impedance of the cable. In fig.3 the voltage at the end of the cable is shown by using filter.

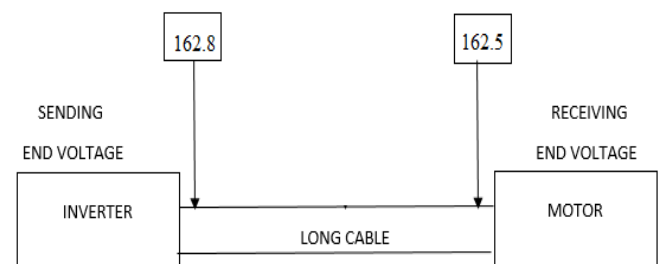

Fig.3. voltage of the cable with filter

The proposed design filter in which the resistance of the filter is equal to the characteristic impedance of the cable. Thus, the characteristic impedance of the cable is higher than the input characteristic impedance of the motor. Therefore, impedance matching at low frequencies around 100-200Hz.

TABLE I

Filter components	
R	70Ω

C	0.075μF
L	3.7mH

But, the overvoltage phenomena occur for high frequencies such as 100's of KHz. Here, the filter is proposed to match the resistance of filter to the cable characteristic impedance for high frequencies. The value of filter component is shown in the Table I.

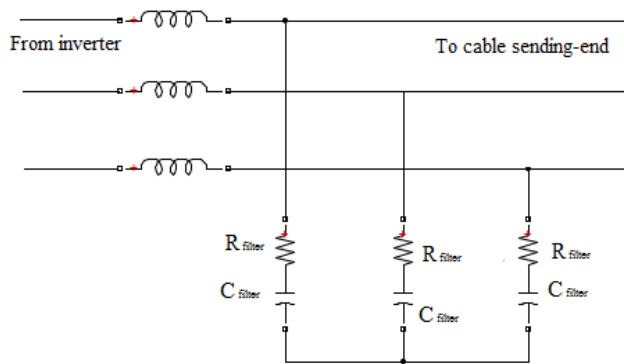

Fig.4 RLC filter at the inverter output

In order to choose the filter value, the losses should be in lower range. Thus, the lower value of the filter will make the motor experience lower line peak voltage. Here, filter capacitance is used for reduced filter loss and peak voltage. Here, filter capacitance is used for reducing filter loss and peak voltage. The RLC filter is shown in fig.4. The RLC filter is used at the end of the cable to reduce the overvoltage phenomena. By using this filter the overvoltage stress in the motor insulation is reduced. The damping ratio for the filter is given below.

The exponential form of damping ratio for filter is given as,

$$\exp(-\omega_n \tau_{rise})(1 + \omega_n \tau_{rise}) = 0.9 \quad (4)$$

The damping ratio of filter is given by,

$$2\omega_n = \frac{2L_{filter} + |Z_{surge-cable}| R_{filter} C_{filter}}{L_{filter} C_{filter} (2R_{filter} + |Z_{surge-cable}|)} \quad (5)$$

$$\omega_n^2 = \frac{|Z_{surge-cable}|}{L_{filter} C_{filter} (2R_{filter} + |Z_{surge-cable}|)} \quad (6)$$

Significant use of choosing, filter capacitance value and thereby, desired peak voltage is obtained with reduced filter loss. Therefore, by increasing filter capacitance, which increases the filter losses and line-line peak voltage decreases[7].

V. SIMULATION AND RESULTS

This model includes rectifier, filter, PWM inverter, cable and induction motor blocks. High switching speeds and zero switching loss, improves the performance of the PWM inverters. The output voltage of the inverter is fed to the cable, at the end of the cable overvoltage occurs, which is the input voltage to the induction motor. To reduce the overvoltage phenomenon here RLC filter is used at the motor terminals, which is terminated at the end of the cable.

The fig.5 shows the schematic representation of long cable leads on PWM inverter fed induction motor drive systems. The modelling and simulation of the whole system has been done in MATLAB-SIMULINK environment.

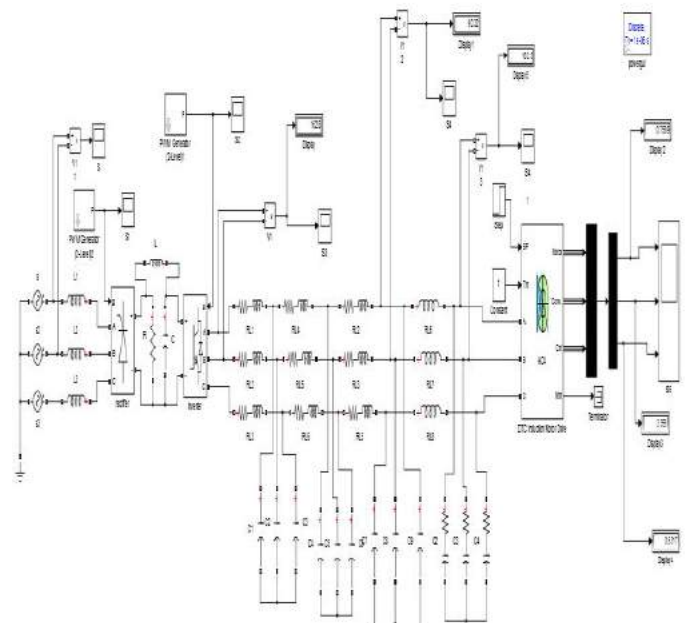

Fig.5. Simulink model of long motor cable leads on PWM inverter fed induction motor systems with filter

The fig.5 shows the schematic representation of long cable leads on PWM inverter fed induction motor drive systems. The modelling and simulation of the whole system has been done in MATLAB-SIMULINK environment.

A. Inverter output

The fig.6 waveform shows the inverter output voltage, and the voltage is shown in the display block by using simulink library.

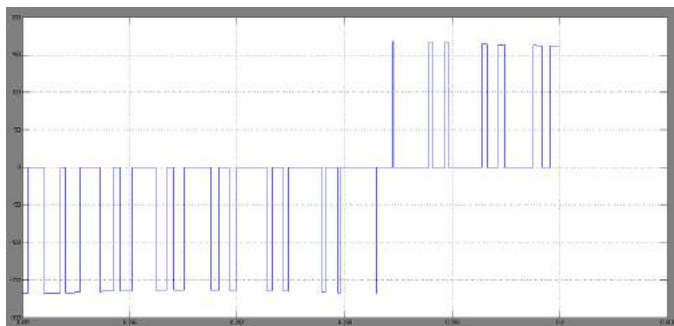

Fig.6 output voltage waveform for inverter

The PWM inverter used here is about 460-V insulated gate bipolar transistor (IGBT), connected to the induction motor drive through cable. The output of the inverter is 162V, which is shown the fig.2.

B. Cable voltage at the middle

The fig.7 waveform shows the sending end voltage of the cable. The values of cable impedance and capacitance are 0.01273Ω, 0.9337mH and 0.07μF respectively. The voltage at the middle of the cable is about 272.8 V, which is shown in the display block. If long motor is operated without filter means overvoltage exists. To reduce the overvoltage, here filter is used and the issues are solved.

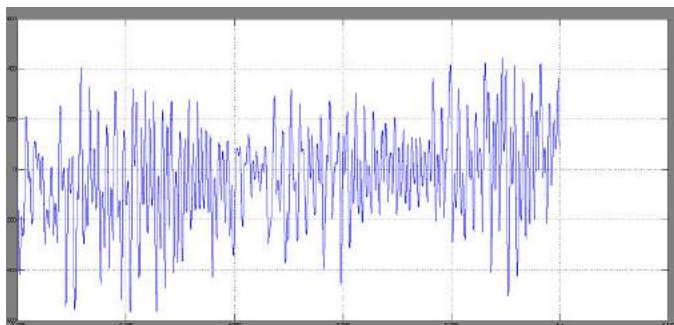

Fig.7 output voltage waveform at the sending end of the cable

C. Voltage at the cable end

In the above fig.8, Overvoltage occurs at the receiving end of the cable, which is taken as input to the induction motor drive. So, As mentioned earlier, the overvoltage occurs at the motor terminals, So RLC filter is used to reduced the overvoltage issues and the results are shown.

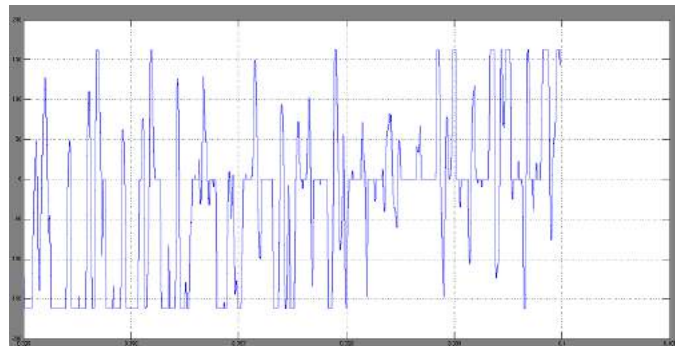

Fig.8.output voltage waveform at the receiving end of the cable

D. Motor output

In fig.4 the inverter output voltage is shown, which represents the voltage waveform. In fig.9 hall effect, rotor speed, stator back emf from the motor is shown.

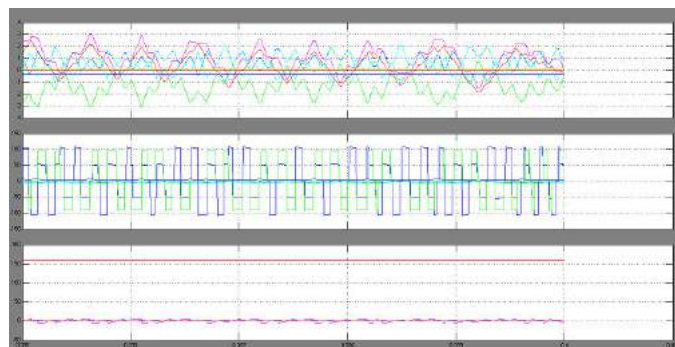

Fig.9.output of motor such as rotor speed, back emf, hall effect

The above effects such as overvoltage, ringing, stress in motor terminals will be minimized by filtering techniques or by using damping circuits. The voltage at the receiving end of the cable is about 162.5V, which does not harm the induction motor. The effects of long motor leads will be reduced, by using filtering techniques.

The power rating of the motor is about 60W. The above waveform shows the rotor speed, stator back EMF and hall effect signal from the induction motor drive systems. The overvoltage from the cable, which harms the motor. So, filtering techniques is used to minimize the effects of long motor leads.

VI. CONCLUSION

The performance of a long motor lead on PWM inverter fed induction motor drive systems is studied by simulating the system in MATLAB environment. A motor of induction motor is chosen, which is connected with the leads and the results are shown. The effects such as overvoltage, ringing, dv/dt occurs at the motor terminals are examined and presented for discussion. The suppression methods are

International Journal of Advanced Research in Basic Engineering Sciences and Technology (IJARBEST)
Vol.3, Special Issue.24, March 2017

studied. The power rating of the motor is 60w and the output voltage of the inverter is 162V. At the end of the cable, voltage takes place such as 194V is obtained by without filter. Therefore, by using the filter the same voltage is obtained as sending end (162V). In addition, the cable length on the voltage magnitude at the terminals of the motor is illustrated. For the cable, the values of impedance and capacitance are 0.01273Ω , 0.9337mH and $0.07\mu\text{F}$ respectively. The voltage at the receiving end of the cable near the motor is 162V and the results are shown.

References

- [1] E. Persson, "Transient effects in applications of PWM inverters to induction motors," *IEEE Trans. Ind. Appl.*, vol. 28, pp. 1095–1101, Sept./Oct. 1992.
- [2] R. Kerkman, D. Leggate, and G. Skibinski, "Interaction of drive modulation and cable parameters on AC motor transients," in *Conf. Rec. IEEE-IAS Annu. Meeting*, vol. 1, San Diego, CA, 1996, pp. 143–152.
- [3] A. Von Jouanne, D. Rendusara, and P. N. Enjeti, "Filtering techniques to minimize the effect of long motor leads on PWM inverter-fed AC motor drive systems," *IEEE Trans. Ind. Appl.*, vol. 32, pp. 919–926, July/Aug. 1996.
- [4] A. Von Jouanne and P. N. Enjeti, "Design considerations for an inverter output filter to mitigate the effects of long motor leads in ASD applications," *IEEE Trans. Ind. Appl.*, vol. 33, pp. 1138–1145, Sept./Oct. 1997.
- [5] N. Aoki, K. Satoh, A. Nabae, "Damping circuit to suppress motor terminal overvoltage and ringing in PWM inverter-fed AC motor drive systems with long cable leads," *IEEE Trans. Ind. Appl.*, vol. 35, no. 5, Sept./Oct. 1999, pp. 1014–1020.
- [6] A. Von Jouanne, P. Enjeti, and W. Gray, "The effects of long motor leads on PWM inverter fed AC motor drive systems," in *IEEE APEC Conf.*, 1995.
- [7] A. F. Moreira, T. A. Lipo, G. Venkataramanan, and S. Bernet, "High frequency modeling for cable and induction motor overvoltage studies in long cable drives," *IEEE Trans. Ind. Appl.*, vol. 38, no. 5, pp. 1297–1306, Sept./Oct. 2002.
- [8] G. Skibinski, "Design methodology of a cable terminator to reduce reflected voltage on AC motors," in *Conf. Rec. IEEE-IAS Annu. Meeting*, San Diego, CA, 1996, pp. 153–161.
- [9] Boris Mokrytzki, "Filters for Adjustable Frequency Drives," *IEEE APEC Conference Proceedings*, 1994, pp. 542–548.
- [10] S. J. Kim and S. K. Sul, "A novel filter design for suppression of high voltage gradient in voltage-fed PWM inverter," in *Proc. IEEE APEC'97*, vol. 1, Atlanta, GA, Feb. 23–27, 1997, pp. 122–127.
- [11] J. M. Erdman, R. J. Kerkman, D. W. Schlegel, and G. L. Skibinski, "Effect of PWM inverters on ac motor bearing currents and shaft voltages," *IEEE Trans. Ind. Appl.*, vol. 32, pp. 250–259, Mar./Apr. 1996.