

DESIGN OF ELEGANT METROPOLITAN AREA USING IOT GATEWAY AND PROTOCOLS

Hema.P¹Dr.V.Saravanan²

¹PG Scholar, M.E (Embedded System Technologies), Jeppiaar SRR Engineering College, Chennai.

²Assosiate Professor, Jeppiaar SRR Engineering College, Chennai.

ABSTRACT: Now a days the humans need ever thing smart and to be done automatic and quick. Automatic evaluation of the requirement reduces the man power and the time. Here we propose and implement a model of a self groomed city. The self groomed city depicts that the infrastructure, government, technology used should be in a smart way. We employ the notion of Internet of Things and its protocols. Internet of Things is a budding technology which is the union of wireless technology, embedded systems and internet. Its main use is to manage and control the process from anywhere in the world. And one more advantage is that we get continual status of the city through cloud. We make use of different sensors to read the status of different modules in a city and the gateway called Raspberry Pi which plays the main responsibility of collecting the sensor values and feeding it into a cloud. The two main modules in this project include environment management and energy management.

KEYWORDS: Cloud, Gateway, Internet of things, Sensors, Self groomed city

I. INTRODUCTION

The smart city is a city that involves implementation of advanced technologies to make it elegant or intelligent. The smart city in sense represents a city with smart people, smart government, smart infrastructure, environment etc. The city usually includes a living environment which consists of houses, hospitals, offices and the pathways that connect these structures. The traffic is controlled by the traffic police .In case if an accident occurs it is informed by the public or by a traffic police to the nearby hospital. Taking into account the disposal of wastes, a periodic monitoring is done manually by visiting the streets. Considering the street lights, it is glowing continuously consuming the power unnecessarily. People are burning the wastes then and there at nearby places. Finally children, speakers are making noises nearer to the houses which make the humans get irritated.

The traffic is controlled using microcontrollers such as 8051, PIC etc., and based on traffic congestion also the traffic was controlled. This Project deals with detection and informing about the accident that occurs during the traffic congestion. Here the vehicle is fitted with a vibration sensor which when disturbed indicates the abnormality. The wastes management is done by timely disposal of wastes. Here the dustbin is fitted with Light Dependent Sensor connected in series with the capacitor. Depending on the light

intensity the range of the bin is calculated and hence the amount of wastes. Street Lights are burnt only when an obstacle is detected which is carried out by means of Proximity and infrared sensor. By burning the wastes the air is getting polluted which may cause some illness to young children and old age people who are nearby. Any actions like burning of unwanted wastes at unnecessary places are monitored and controlled.

II. RELATED WORK

The paper titled “ Internet Of things for smart Cities” by Andrea zanella ,Senior Member IEEE., Nicola Bui, Angello Castellani, Lorenzo Vangelista, senior member IEEE,Michele Zorzi, Fellow IEEE appeared on 2014 is a complete survey about the design of urban IoT and the technologies and methods used to implement the design. They have given ideas what are the modules to be included in the smart city. The paper proposes the use of one of the IoT protocols namely constrained Application Protocol. The used cases discussed in this project are structural health monitoring, Noise monitoring, Traffic congestion, waste management, air quality control etc. The City considered here is the Padova in Italy. This paper also discusses the specifications for the services such as structural health monitoring, waste management, air quality monitoring, traffic congestion, smart parking and smart lightning. The usage of CoAP leads to usage of more bandwidth.

International Journal of Advanced Research in Basic Engineering Sciences and Technology (IJARBEST)
Vol.3, Special Issue.24, March 2017

The paper titled “ Review paper for Smart City” by Pinank R.Patel., M.E Civil Engineering Sarvajani College Of Engineering and Tech., Surat , Gujarat, India , Himanshu J. Padhya , Associate Prof., Civil Engg., Sarvajani College of Engg and Tech., Surat ,Gujarat, India appeared on International Journal Of Advanced research in Engineering , Science and management discuss about the specification of a smart city, the components of elements of a smart city and also definitions of a smart city given by various people and countries . This paper concentrates on cities such as LAVASA and GIFT. Since it is a review paper, it discusses various papers on smart city.

The paper titled “Every thing You Wanted to know About Smart Cities” by Saraju P.Mohanty, Uma Choppalli and Elias Kougiannos appeared July 2016 in IEEE Consumer Electronics Magazine provides an clear and complete information regarding a smarter city. The smart city should contain the following scenario such as the smart governance, smart home, smart people, smart agriculture, smart education, smart technology, and smart infrastructure. The smart governance deal that the Government should be robust. The smart technology includes the usage of Wi-Fi and 4G and implementation of Information and communication technologies for the country to be smart. The infrastructure of the smart city includes physical aspects, ICT, and services. The smart transportation system helps the people to select low cost and reliable transport. At last it discuss about the advantages of the smart city concept.

The paper titled “Smart city: definitions, Initiatives, Dimensions and Performance” by Vito Albino, Umberto Berardi and Rosa Maria Dangelico appeared in Journal of Urban Technology, 2015 provide the definitions from many sources , initiatives that induce the concept of developing a smart city,etc. According to many sources the definitions and the dimensions of the smart city varies and those are discussed in this paper

The paper titled “Intelligent Traffic Light Controlling Algorithms using vehicular networks” by Maram Bani Younes and Azzedine Boukerche, Fellow, IEEE in IEEE Transactions on Vehicular Technology, August 2016, describes the traffic management through the knowledge of vehicular networks. The concept is that the use of Intelligent Traffic light control algorithm (ITLC) and arterial Traffic light algorithm to schedule the traffic. The communication is through the Network Simulator 2. This method reduces the delay and has

efficiency increased by 30% compared to the online traffic monitoring system

The paper titled “Energy efficient Outdoor light monitoring and Control Architecture Using Embedded System” by Zeeshan Kaleem, Tae min Yoon and Chankil Lee in IEEE Embedded system Letters, March 2016 is concerned about the efficient outdoor energy management. Here they have used the concept of Zig-bee and had got the power saving of 70%. The use of the technique such as Wi-Max and GPRS resulted in the interference of both users. Hence they developed this energy control technique using Zig-Bee, Sensors and Embedded system

The Paper titled “Smart Home Energy Management System Including Renewable Energy Based on ZigBee and PLC” by Jinsoo Han , Chnag-Sic Choi, Wan-Ki Park, Ilwoo Lee , and Sang-Ha Kim in IEEE Transactions on consumer electronics ,May 2014, deals with the measurement of electric power consumption by home appliances. The Home Energy Management System(HEMS) measures the energy consumed periodically through the energy measurement and communication unit. It collects the data and sends it to the server and the server controls the appliances regarding the abundant usage and in absence of a human. The techniques used include Zig-Bee and Power line Communication (PLC)

III. EXISTING SYSTEM

The concept of smart city is an emerging one. The individual modules of a smart city that we have considered in this project have been implemented in various cities. First of all considering the traffic management. the used cases are many such as monitoring the traffic based on the congestion, diverting the route based on the traffic or else intimating the accident occurrence and automatic signal control etc. then taking into consideration the disposal of wastes the dustbin is continuously monitored with the help of sensors and once it is filled it is intimated to the person who is responsible for that. Considering the street light monitoring the existing used cases are like controlling the street lights based on the presence of persons or vehicle. Then considering the air pollution the projects have been like monitoring the pollution content. Finally the home automation deals with monitoring the power consumption of a house on that particular day and intimating into the electricity board. Finally the existing system has every modules implemented separately and also they have only made survey and discussed about

the technologies that can be implemented in a smart city.

IV. PROPOSED SYSTEM

This system involves the implementation of the proposed ideas for making a smart city. The main concept here is the use of Internet of things for monitoring and controlling the status of the city. Therefore the modules discussed individually are done together as a single system

INTERNET OF THINGS

The Internet of Things (IoT) is a system of computing devices that are interrelated computing devices as well as it includes mechanical machines, objects, humans provided with a unique ID and those have the ability to communicate each other without a personal computer to human as well as human to human interaction. This Internet of Things is an emerging concept that can be implemented in various concentrations such as smart home, smart hospitality, smart irrigation, smart traffic management etc. the main advantage is that there is a perpetual update of the system to which it is connected. There are protocols of the IoT for bartering the data that too for different layers such as network layer, session layer and medium access layer etc which includes some like MQTT, XMPP, CoAP, 6LowPAN etc. IoT data management technologies ensure that you can collect the right data at the right time, even when connectivity is interrupted. The communication between devices is carried by means of the IP address.

V. HARDWARE REQUIREMENTS

1. GATEWAY

The gateway must be such that it must support the used cases for the smart system. For example it must support the Internet of things protocols, the language used etc., therefore the gateway that supports these features are chosen and that is the Raspberry Pi. It is a credit card sized computer. It is also called as single board computer it means that it can act as a computer. The operating system should be fed into the board with the help of the SD card. The OS that is recommended is the Raspbian which is an open source. There are various models in Raspberry Pi from the first piece of manufacturing. The models some are zero, A, B, A+, etc. The first model is the Pi zero. These models lack the Ethernet and USB hub components. The boards in general have a

Broadcam system on chip, On-chip Graphics processing unit, HDMI and Video output.

The model used in this project is the Broadcam 2836 SoC with a 900 MHz 32-bit quad-core ARM Cortex-A7 processor. This has more GPIO pins and can be programmed in two ways either in BCM or Board. Here we use a 40 pin board. The SD card is used to install the Raspbian OS into the computer.

2. LIGHT DEPENDENT RESISTOR

A light dependent resistor (LDR) is also called a photo resistor or a cadmium sulfide (CdS) cell. It is also called a photoconductor. It is basically a photocell that works on the principle of photoconductivity. The passive component is basically a resistor whose resistance value decreases when the intensity of light decreases. This optoelectronic device is mostly used in light varying sensor circuit, and light and dark activated switching circuits. Some of its applications include camera light meters, street lights, clock radios, light beam alarms, reflective smoke alarms, and outdoor clocks. LDR's are cheap and are readily available in many sizes and shapes. Practical LDRs are available in a variety of sizes and package styles, the most popular size having a face diameter of roughly 10 mm. They need very small power and voltage for its operation. The disadvantage includes highly inaccuracy with a response time of about tens or hundreds of milliseconds.

3. VIBRATION SENSOR

The Vibration module is based on the vibration sensor SW-420 and Comparator LM393 to detect if there is any vibration that beyond the threshold. The threshold can be adjusted by the on-board potentiometer. When there is no vibration, output is logic LOW the signal indicate LED light, and vice versa. The application of such sensor includes detection of the vibration and in burglary protection system.

4. IR SENSOR

An infrared sensor is used to sense the obstacle be either emitting or detecting the infrared radiation. They are also capable of sensing the heat emitted by an object. The key benefit of this sensor is the low power consumption, simple circuitry and portability. All objects which have a temperature greater than absolute zero possess thermal energy and are sources of infrared radiation as a result.

5. CURRENT SENSOR

The current sensor is a device that detects the electrical current in a wire which is the input to it

and generates a signal proportional to it. The output from the sensor can be an analog or current value or even a digital one.

6. AIR SENSOR

Air pollution sensors are used to detect the presence of air pollution in the surrounding area. The sensor mainly focuses on gases such as ozone, particulate matter, carbon mono oxide, sulphur dioxide and nitrous oxide.

7. NOISE SENSOR

The function of this sensor is to sense those signal that cause noise pollution. Here we use this sensor to detect the heavy noises made by the loudspeakers unnecessarily.

VI. BLOCK DIAGRAM

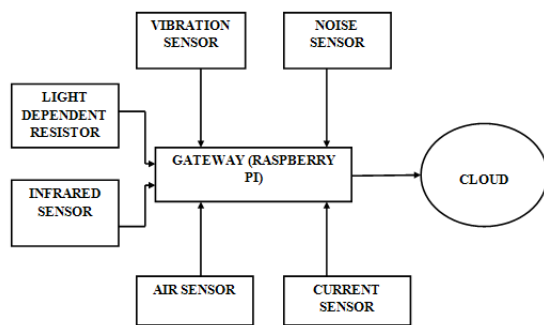

The data from the sensors are sent to the gateway through wires and the gateway and cloud communicate using the IoT protocol named MQTT. We push the data to the cloud with the help of a MQTT protocol. There are many protocols of IoT for various layers. The graphical view is created by means of a software named NODERED. This is the software used in case of IoT like Visual Basic for other controllers. “MobaXterm” is the software used to view the process in the gateway locally.



Fig: A view of the “MobaXterm” software

VII. PROJECT DESCRIPTION

The two main modules included are energy management and environment module. The energy management includes the street light monitor and control and the monitoring of the power consumption in homes. The environment module includes the noise pollution monitoring, air pollution detection, waste management and traffic management.

ENERGY MANAGEMENT MODULE

STREET LIGHT CONTROL

Here we demonstrate this model by using the infrared sensor placed opposite to the street lights. When the obstacle like a car or any vehicle or any person enter the street the rays are detected by the sensor thereby it turns on the street lights. This method can avoid the unwanted consumption of power in absence of any persons or vehicle in the streets. To prevent the entry from various directions we can place the infrared sensor at the top angle so that a range of area can be covered. Or else to make more beneficial an infrared sensor can be replaced by an ultrasonic sensor.

HOME AUTOMATION

Now days a home almost contains a television, refrigerator, an AC, washing machine etc. The used case in this project is to periodically monitor the power consumption in a home. So we implement here using the current sensor. The power consumed in a home is given as input to the current sensor which is capable of generating a digital output corresponding to it. This data is fed into the controller and thereby the information is viewed by the owner.

ENVIRONMENT MANAGEMENT MODULE

WASTE MANAGEMENT

Usually we know every street contain a dustbin at its end and the wastes are being put into it. The point is that those bins are not timely cleaned. We can see the bins that will be over loaded which further cause the diseases and bad smell. Here we have done like intimating the concerned person responsible for the disposal of the particular dustbin and to the local authority. Each dustbin is provided with a unique identifier so that the dustbin which is filled can be easily identified in the server. Here we use a circuit that consists of a light dependent sensor and a capacitor. The light dependent resistor varies the resistance based on

the light intensity. So here we fix two LDRs, one at the middle and another one at the top from which we can identify the level up to which the dustbin is full.

AIR POLLUTION CONTROL

In the present scenario the pollution is increasing vastly due to the emission of harmful gases. In addition to that people burn the wastes unnecessarily in the places where they should not do. There is a place for the burning of wastes. Hence to monitor those abnormalities we place an air sensor that identifies the occurrence of pollution. This module is to avoid the burning of wastes at unnecessary places. In real time the balloon over the city can be placed to cover a large area for monitoring the pollution occurrence.

NOISE POLLUTION CONTROL

The parks are located near houses and in case of functions they make use of loudspeakers which there by affects the children and heart patients and people nearby. The range of sound will cause an irritation. There is no way to control those situations other than intimating the local authority. So we make use of a noise sensor to monitor the noise pollution occurrence.

TRAFFIC MANAGEMENT

The traffic management has many senses such as monitoring and controlling the traffic according to the traffic intensity, intimation of the accident to the nearby police station etc. but the used case here is the intimation of traffic to the proceeding and preceding signal so that the drivers can divert their routes. The occurrence of an accident is intimated to the nearby hospitals and the police station. The accident occurrence is sensed by the vibration sensor that will be placed in a vehicle.

CONCLUSION

Thus we have implemented the suggested methodologies to design a smart city. The street light module is demonstrated using the Infrared sensor, waste management is through the light dependent resistor, accident is sensed with the help of vibration sensor, and finally the data is pushed into the cloud and monitored. This is how we monitor the status of the city using Internet of Things.

REFERENCES

- [1] P.Suresh1J. Vijay Daniel2, Dr.V.Parthasarathy4” A state of the art review on the Internet of Things (IoT)” International Conference on Science, Engineering and Management Research (ICSEMR 2014)
- [2] “City Garbage collection indicator using RF (Zigbee) and GSM technology”
- [3] Vikrant Bhor, Pankaj Morajkar, Maheshwar Gurav, Dishant Pandya4 “Smart Garbage Management System” International Journal of Engineering Research & Technology (IJERT) ISSN: 2278-0181 IJERTV4IS031175 Vol. 4 Issue 03, March-2015
- [4] Archana. G, Aishwarya N, Anitha J “Intelligent Street Light System” International Journal of Recent Advances in Engineering & Technology, Vol-3, Issue-4, 2015.
- [5] DeepanshuKhandelwal, Bijo M Thomas, KritikaMehndiratta, Nitin Kumar “Sensor Based Automatic Street Lighting system” International Journal of Education and Science Research Review Volume-2, Issue-2 April- 2015 .
- [6] IsahAbdulazeez Watson, OshomahAbdulaiBramiah, Alexander Omoregie “ Design and Implementation of an Automatic Street Light Control System” International Journal of Emerging Technology and Advanced Engineering, Volume 5, Issue 3, March 2015
- [7] Mustafsaad, AbdalhalimFarij, Ahamed Salah “Automatic Street Light Control System Using Microcontroller” Mathematical method and Optimization Technique in Engineering ISBN: 978-960-474-339-1.
- [8] Nupur Tyagi, “A REFERENCE ARCHITECTURE FOR IoT”,in International Journal of Computer Engineering and Applications, Volume X, Issue I, Jan. 1www.ijcea.com ISSN 2321- 3469
- [9] SomayyaMadakam, R. Ramaswamy, SiddharthTripathi, “Internet of Things (IoT): A Literature Review”, Journal of Computer and Communications, 2015, 3,164-1
- [10] Kosmatos, E.A., Tselikas, N.D. and Boucouvalas, A.C. (2011) Integrating RFIDs And Smart Objects into a Unified Internet of Things Architecture. Advances in Internet of Things: Scientific Research, 1, 5-12.
- [11] Souza, Alberto M.C. Amazonas, Jose R.A. “A Novel Smart HomeApplication Using
- [12] Aggarwal, R. and Lal Das, M. (2012) RFID Security in the Context of “Internet of Things” First International Conference on Security of Internet of Things, Kerala, 17- 19 August 2012, 51-56.