

# SMART TRAFFIC SYSTEM TO REDUCE TRAFFIC CONGESTION IN METRO-CITIES USING EMBEDDED SYSTEM

Mukesharavind P<sup>1</sup>, Prakash M<sup>2</sup>

<sup>1</sup>PG Student, Excel College of Engineering and Technology, Namakkal, Tamilnadu

<sup>2</sup>Assistant Professor / ECE, Excel College of Engineering and Technology, Namakkal, Tamilnadu

**Abstract:** The existing traffic light control system is based on the fixed waiting time on each lane, which leads to waste of time and fuel. Currently the system is adapting to variable timing system, but that too with some segments of constant timing blocks and it doesn't lead to fully flexible timing independence system. In proposed system traffic light control system with priority of time is implemented its operation; hence it will be the complete solution for modern traffic light control system. The scheduling (pre-emptive) is implemented to control and calculate the waiting time for each lane, based on the sensor module presented in lane. The implementation of four lane system with three sensors on each lane helps to provide the details for life time of task, so it leads to four independent tasks. The task which has highest deadline has the high priority and it will be processed first based on the scheduling. In LabVIEW, the sensors module can be present in each lane and it's to be activated by traffic vehicles in the lane can be graphically represented by using LabVIEW. Keil  $\mu$ Visions is software that combines project management, source code editing, program debugging and complete simulation. The simulation

outputs of the proposed system are implemented in the UART window.

**Key Words:** ATmega2560 Microcontroller, Infra-Red Sensor, Pre-emptive Scheduling.

## I. INTRODUCTION

Vehicular traffic is continuously increasing around the world, especially in Metro Cities. The present Traffic Light Controller (TLC) is based on microcontroller. Which have limitations to uses the pre-defined hardware, and it is functioning according to the program that does not have the flexibility of modification on real time basis. Due to the fixed time intervals of green and red signals the waiting time is more and car vehicle consumes fuel. To make traffic light controlling more efficient, a new technique is implemented called as "Smart Traffic System to Reduce Traffic Congestion in Metro-Cities Using Embedded System". This makes the use of Sensor modules along with Real time systems. The timing of Red, Green lights at each crossing of road will be intelligently decided based on the total traffic on all adjacent roads. Thus, the

optimization of traffic light switching increases road capacity and traffic flow, and can prevent traffic congestions.

In the proposed system, the advanced microcontroller is controls all sub devices connected across it. The flash type reprogrammable memory is used in the microcontroller to enhance the project as more efficient.

The sensor is the input device in this project to measure number of vehicles present in the lane. The sensor output is given to amplifier unit and it amplifies the signal. Then the output signal is given to the microcontroller for programming to manage the lane vehicles without any disturbances By using the microcontroller it can be compared and controlled automatically [1-5]. The lane comparison can be graphically represented by using LabVIEW. Keil  $\mu$ Vision software is used to extract output from UART window. The manual inputs given are compared automatically and the maximized number will be executed by scheduling (pre-emptive) based.

The Main Objective of the project is to reduce the vehicular waiting time in the heavy traffic congestion area. The waiting time is to be minimized by Atmega2560 microcontroller by implementing the Pre-emptive Scheduling. This can be also used to minimize the usage of fuel (source) and time consumption for users. The output can be obtained by using the LabVIEW and Keil  $\mu$ Vision software. It is used for the consumers to travel in the traffic signals without any disturbances of time.

The Modern Traffic light control system is used for controlling the traffic system with no constant timing delay. The pre-emptive scheduling in this proposed method is used to minimize the waiting time with high priority lane in vehicle position by using LabVIEW, and it shows the graphical representation for the parameters and additionally in UART window of Keil  $\mu$ Vision software.

## II. LITRATURE REVIEW

Asif Ahmad, et al [1] did the comparative study of Traffic Light control system for ATLC Algorithm on High Priority Vehicles. One of the major problems, caused by traffic congestion, owes its existence to the unwanted delay experienced by the priority vehicles. The evaluation of two scheduling algorithms as adaptive traffic control algorithms has been proposed here to reduce this unwanted delay. One of these algorithms is the earliest deadline first (EDF) algorithm, whereas the other is the fixed priority (FP) algorithm. The performance of both algorithms as adaptive traffic light control algorithms is evaluated for isolated traffic intersections.

Vivek Kumar Sehgal, et al [2] proposed the adaptive traffic control system where the long traffic jams and it's executed the automated intelligent traffic control by sensor based system. A change in timing of Traffic lights has adverse effects on traffic. A change applied too early may lead to congestion on other roads and a change too late may wreak havoc; long traffic jams, instance of road rage, accidents etc. The ideal automated traffic signal is yet to be built. This report

presents an adaptive traffic control system where the traffic load is continuously measured by sensors connected to a microcontroller-based system. The traffic lights of an area are interconnected with a communication network through which traffic load and synchronization information is exchanged. As a result, the duration of each traffic light cycle changes dynamically. This means that the timing of the traffic light changes according to the load, the side with the greatest load is given time wise priority.

Shilpa S. Chavan, et al [3] implemented the Intelligent traffic light controller, This techniques are to reduce the traffic congestion by using sensor networks along with Embedded Technology in the timings of Red, Green lights at each crossing of road and the traffic position details to be communicate the wireless network (GSM cell phone). The use of Sensor Networks along with Embedded Technology. The timings of Red, Green lights at each crossing of road will be intelligently decided based on the total traffic on all adjacent roads. Thus, optimization of traffic light switching increases road capacity and traffic flow, and can prevent traffic congestions. GSM cell phone interface is also provided for users those who wish to obtain the latest position of traffic on congested roads. This is a unique feature of this project which is very useful to car drivers to take an alternate route in case of congestion. The various performance evaluation criteria are average waiting time, average distance travelled by vehicles, switching frequency of green light at a junction, efficient emergency mode operation and

satisfactory operation of SMS using GSM Mobile.

Rashid Hussian, et al [4] proposed automated traffic control system uses a simple time based system which working on a time interval basis which is now inefficient for random and non-uniform Traffic. Advance automated systems in testing use image processing techniques or advance communication system with an intelligent information gathering systems in vehicles to communicate with signal and ask for routing. This might be implementable in developing countries as they are more complex and expensive.

Li Li, et al [5] did a survey of improving the efficiency of traffic control system. The aim of survey is to improving the traffic efficiency via vehicle-to-vehicle communications. The design philosophy for traffic control systems is undergoing a vehicles transition and it's used for three pair of control system of vehicles communication.

Giorgio C. Buttazzo, et al [9] did the survey of pre-emptive scheduling algorithm are better than the non-pre-emptive scheduling in the real-time tasks and to reducing preemptions and compares them under different metrics, providing both qualitative and quantitative performance evaluations. The pre-emptive algorithms are better than non-pre-emptive ones for scheduling a set of real-time tasks has been debated for a long time in the research community.

### III. PROPOSED METHOD

In order to overcome the problem in the conventional method, the proposed system is employed. In proposed system waiting time of the vehicle in the lane are reduced by pre-emptive scheduling. The advanced microcontroller (ATmega2560) consumes less power and it can be easily altered and number of devices can be connected according to the input and output ports.

In the proposed system, the pre-emptive scheduling is implemented in the real time embedded system. Pre-emptive scheduling, tasks are assigned with priorities. At times it is necessary to run a certain task that has a higher priority before another task although it is running. Therefore, the running task is interrupted and the higher priority task is to be executed.

There are three sensors present in each lane of the traffic light system. The sensor modules present in each lane are to be compared by the pre-emptive scheduling based and the higher priority is to be executed. So the waiting traffic congestion time is reduced accordingly and consumes the fuel to prevent pollution.

Whenever anyone of the lane gets more number of vehicles, that lane will be executed first and other lanes are follows as per priority. This task performs continuously by advanced microcontroller and it can be controlled automatically. The lane comparison can be graphically represented by using LabVIEW.

- The modern urban traffic light system can be done by using pre-emptive scheduling.

- Reduction of all vehicular traffic congestion in Metro Cities.
- There is no constant waiting time in its operation.
- According to the input and output ports, number of the devices can be connected by using ATmega2560 microcontroller.
- High efficiency output can be obtained by using sensor module.

#### IV. HARDWARE DESCRIPTION

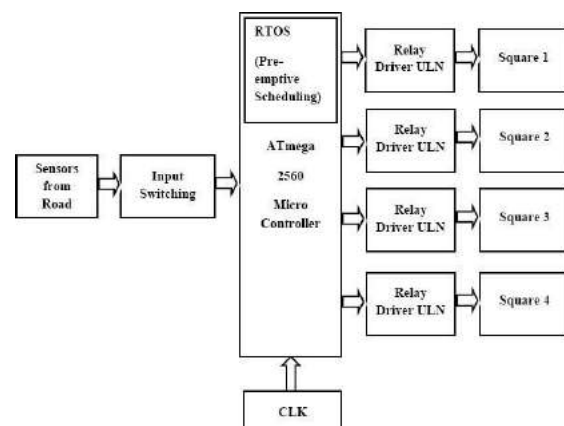

Fig. 1 Block diagram of Proposed System

The system mainly operated by ATmega2560 microcontroller. In this project it consists of sensor module that is present in four lanes and it is used to detect the input. The sensors can be connected to the input switching circuit like as amplifier and it amplifies the sensor sensing input signal.

In the advanced microcontroller, it converts the analog to digital signal through inbuilt ADC. It can be given to the driver circuit and it is used to convert the signal in the required form of controller. The signals can be connected to the relay driver and it is an electrically operated switch and current flowing through the coil of the relay creates a magnetic field which attracts a lever and changes the switch contacts.

The square acts as LEDs for traffic light terminals. These traffic light lamps can be driven by a relay which is switched through a transistor. The base terminal of transistor is connected with the microcontroller output. These are implemented by using the advanced microcontroller. It can be graphically represented by using the LabVIEW.

In this project, the methodology used here are pre-emptive scheduling based on the real time embedded system. By using the LabVIEW and Keil  $\mu$ Vision software, the sensor module present in each lane are to be compared by the pre-emptive scheduling and the higher priority lane side is to be executed. The sensor modules are compared randomly and it can be automatically controlled by using the ATmega2560 microcontroller. The lane comparison can be displayed by using the LabVIEW. According to this, it is very easy to understand the lane comparisons.

## V. RESULTS ANALYSIS

### LabVIEW SOFTWARE RESULTS

It indicates the parameters are in traffic light system of graphical representation by using LabVIEW.

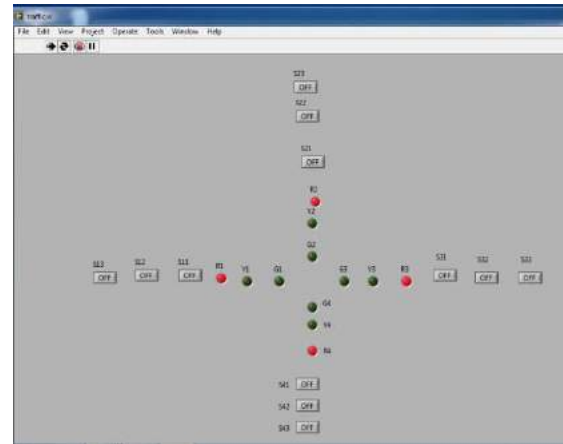

**Fig 2. Initial Stage Representation**

The Fig 2 shows that there are no vehicles in any Lane. The sensors are not activated initially. So the Lanes are in stop condition shows the Led glowing as Red.

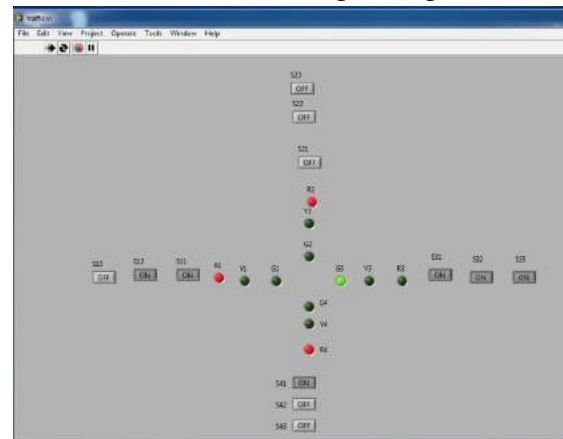

**Fig 3. Execution of Lane 3 Representation**

The Fig 3. Shows that the sensors condition and execution.

In Lane 1, two sensors are in active

In Lane 2, no sensors are in active

In Lane 3, three sensors are in active

In Lane 4, one sensor is in active

By Lane comparison, the highest priority of activated sensors will be executed. So there are more sensors are active in Lane 3 is in Go condition shows that Led Glowing as Green and other Lanes are Red.

In UART Window of Keil  $\mu$ Vision software shows that the lane vehicle numbers and output. The input values of vehicle numbers are given manually. Those manual inputs are 5 vehicles in Lane 1, 2 vehicles in Lane 2, 8 vehicles in Lane 3 and 4 vehicles in Lane 4. These Lanes are compared and highest priority value of vehicles in lane (i.e Lane 3) is executed as Green and the other Lanes are Red.

### Keil $\mu$ Vision SOFTWARE RESULTS

```
UART #1
Welcome To Salem City
Enter no of vehicals
in lane 1      5
in lane 2      2
in lane 3      8
in lane 4      4
lane 3 green
lane 1 red
lane 2 red
lane 4 red
Enter no of vehicals
in lane 1
```

Fig 4. Output for 3<sup>rd</sup> Lane Execution

```
UART #1
Welcome To Salem City
Enter no of vehicals
in lane 1      5
in lane 2      1
in lane 3      0
in lane 4      4
lane 1 green
lane 2 red
lane 3 red
lane 4 red
Enter no of vehicals
in lane 1      2
in lane 2      4
in lane 3      3
in lane 4      7
lane 4 green
lane 1 red
lane 2 red
lane 3 red
Enter no of vehicals
in lane 1
```

Fig 5. Lane Execution of higher priority value

### VI. CONCLUSION

In this project the modern urban traffic light system done by pre-emptive scheduling based and controlled automatically with the support of high speed embedded microcontroller. In proposed system, the waiting time is reduced in the metro cities. By implementing this project, the overall travelling time is minimized for consumers and also the fuel source is consumed. It provides an excellent solution for the existing system by overcoming the drawbacks. The simulation results are obtained by LabVIEW and Keil  $\mu$ Vision software.

The project can be enhanced by increasing the number of lanes in the traffic light system. It can be extended by pedestrian cross by using sensor module in pre-emptive scheduling.

### VII. REFERENCE

[1]. Asif Ahmad, Rabia Arshad, Sahibzada Ali Mahmud, Gul Muhammad Khan, Hamed S. Al-

- Raweshidy, "Earliest-Deadline-Based Scheduling to Reduce Urban Traffic Congestion," IEEE Transaction on Intelligent Transportation Systems, Vol. 15, No. 4, August 2014.
- [2]. Vivek Kumar Sehgal, Samruddh Dhope, Prince Goel, "An Embedded Platform for Intelligent Traffic Control," UKSim Fourth European Modelling Symposium on Computer Modelling and Simulation.
- [3]. Shilpa S. Chavan, Dr. R. S. Deshpande, J.G. Rana, "Design of Intelligent Traffic Light Controller Using Embedded System," Second International Conference on Emerging Trends in Engineering and Technology, ICETET-09.
- [4]. Rashid Hussian, Sandhya Sharma, Vinita Sharma, Sandhya Sharma, "WSN Applications: Automated Intelligent Traffic Control System Using Sensors," International Journal of Soft Computing and Engineering (IJSCE) ISSN: 2231-2307, Volume-3, Issue-3, July 2013.
- [5]. Li Li, Ding Wen, Danya Yao, "A Survey of Traffic Control with Vehicular Communications," IEEE Transaction on Intelligent Transportation Systems.
- [6]. Jia Wu, Abdelijalil Abbas-Turki, Abdellah EL Moudni, "Discrete Methods for Urban Intersection Traffic Controlling," IEEE 978-1-4244-2517. 2009.
- [7]. Li Liu, Yuan Zhou, Ming Liu, Guandong Xu, Xiwei Chen, Dangping Fan, Qianru Wang, "Preemptive Hadoop Jobs Scheduling under a Deadline," 2012 Eighth International Conference on Semantics, Knowledge and Grids.
- [8]. Y.-S. Huang, P.-J. Su, "Modelling and Analysis of Traffic Light Control Systems," IET Control Theory Appl., 2009, Vol. 3. Iss. 3, pp. 340-350.
- [9]. Giorgio C. Buttazzo, Markon Bertogna, Gang Yao, "Limited Preemptive Scheduling for Real-Time Systems. A Survey," IEEE Transaction on Industrial Informatics, Vol. 9, No. 1, February 2013.
- [10]. R. Santhosh, T. Ravichandran, "Pre-emptive Scheduling of On-line Real Time Services With Task Migration for Cloud Computing," Proceedings of the 2013 International Conference on Pattern Recognition, Informatics and Mobile Engineering (PRIME) February 21-22.