

Three phase Inverter Using SVPWM Method for Solar Electric Vehicle

P.Arockia Merlin

J.Beaula
M.Priyanga
G.Sabitha

UG Scholar-Electrical and Electronics
Department^{1,2,3,4}

SSM Institute of Engineering and Technology
Dindigul, Tamil Nadu, India
eeessmiet17@gmail.com

Abstract - Solar electric vehicles (SEV) are considered to be the future vehicles to solve the issues of air pollution, global warming, and the rapid decreases of the petroleum resources facing the current transportation technology. However, SEV are still facing important technical obstacles to overcome. They include batteries energy storage capacity, charging times, efficiency of the solar panels and electrical propulsion systems. Solving any of those problems and electric vehicles will compete - complement the internal combustion engines vehicles. In the present work, we propose an electrical propulsion system based on three phase induction motor in order to obtain the desired speed and torque with less power loss. Because of the need to lightweight nature, small volume, low cost, less maintenance and high efficiency system, a three phase squirrel cage induction motor (IM) is selected in the electrical propulsion system. The IM is fed from three phase inverter operated by a constant V/F control method and Space Vector Pulse Width Modulation (SVPWM) algorithm.

Keywords - Electric Vehicle; Squirrel Cage Induction Motor; SVPWM method; V/F control

I. INTRODUCTION

Efforts to improve air quality in heavily populated urban communities have rekindled interest in the development of electric vehicle technology. However, the key issues which are challenging in the design of electric vehicles are the electric propulsion system, energy sources and battery management system. Solving any of those issues and electric vehicles will compete - complement the conventional internal combustion engines vehicles. This paper will focus in design and performance of electric propulsion system alternative. Direct Current (DC) and Brushless Direct Current (BLDC) motors drives have been widely applied as propulsion system to EVs because of their technology maturity and control simplicity. However, with the emerging technology in switching semiconductors and digital signal processors at reasonable cost led to more interest in using AC induction motors instead of DC motors. The AC induction motors especially the cage type,

have lightweight, small volume, low cost, less maintenance, no commutation, high torque at low speed and high efficiency. These advantages are particularly important for EV applications. In EVs propulsion, an AC induction motor drive is fed from a DC source (battery), which has approximately constant terminal voltage, through a DC/AC inverter. The DC/AC inverter is constituted by a fast switching power electronic switches and power diodes. IGBTs and MOSFETs are commonly used in the inverters configurations. Since the output AC voltage of the inverter has high frequency square wave forms, a high speed processor is needed to produce the proper switching sequence. Various switching techniques are used to generate PWM signal which is used to determine the amplitude and the frequency of the output voltage. Among the various PWM techniques, Space Vector Pulse Width Modulation (SVPWM) has advantages that made it the most switching techniques suitable for electric vehicles. The interesting features of this type of modulation is that it provides better DC-link utilization, more efficient use of DC supply voltage, produce less ripples and increase life time of drive. Furthermore, it can be easily implemented digitally and hence offers the advantage to perform entire digital processing tasks. The performance of SVPWM depends on the type of processor used for its implementation. Among the various processors available in the market, the most popular are the Texas Instrument DSP which holds about 70% of the market. TMS320F2xxx DSP series are high speed processors which have been developed by Texas Instruments especially for industrial control applications, in particular for implementation of SVPWM algorithm to drive the switches of the inverter. In the present paper an electric propulsion system is investigated. The propulsion system constitutes of a three phase squirrel cage induction motor, IGBT-based three phase inverter and advanced processor, such as DSP, implementing SVPWM algorithm for open loop speed control using V/F method of electric vehicle. The V/F is selected because it tries to achieve some features which are suitable. These include wide speed span with constant

motor torque, low starting current, acceleration and deceleration of the vehicle. The paper is organized as follows: first SVPWM technique along with V/F method is discussed, second the mechanical parts of the vehicle are presented, and third the electrical propulsion system is described and finally practical results obtained are presented along with conclusions.

II. SPACE VECTOR PULSE WIDTH MODULATION TECHNIQUE

A number of Pulse width modulation (PWM) schemes are used to control the magnitude and frequency of AC output voltage of the inverter. The most widely used PWM schemes for three-phase voltage source inverters are sine wave sinusoidal SPWM and space vector PWM (SVPWM). Since SVPWM is easily implemented digitally, enable more efficient utilization of DC bus voltage, and generate sine wave with lower total harmonic distortion, it is most frequently preferable technique used in modern AC machines drives fed by inverters. The performance of an induction motor is improved when SVPWM technique is applied. Details explanation of the SVPWM and SPWM techniques can be found in [1]. Although SVPWM is more complicated than sinusoidal PWM, it is easily implemented using modern DSP based control systems. The SVPWM technique implemented into the existing TI Digital Motor Control (DMC) library reduces computation time and the number of transistor commutations. It therefore improves Electro Magnetic Interference (EMI) behavior.

III. V/F CONTROL METHOD

The best way to vary the speed of the induction motor is by varying the supply frequency and voltage level simultaneously. It can be shown that the torque developed by the induction motor is directly proportional to the ratio of the applied voltage and the frequency of the supply. By varying the voltage and frequency, but keeping their ratio constant, the maximum torque developed can be kept constant throughout the speed range. In summary, using the V/F control method the following can be achieved: 1) the induction motor can be run typically from 5% of the synchronous speed up to the base speed (maximum vehicle speed), and the maximum torque generated by the motor can be kept constant throughout this range; 2) the starting current is lower; 3) the acceleration and deceleration can be controlled by controlling the change of the supply frequency.

IV. DESIGN OBJECTIVES

The mechanical structure of the electric vehicle prototype manufactured locally and used in this study is shown in figure 1. The weight, volume and aerodynamic drag and rolling resistance effects have been carefully considered in the design of the body of the vehicle [11]. The design objectives are to attain

maximum speed of 60 km/h with a total weight of 500 kg and acceleration time 0 to 60 km/h below 30 sec. Figure 2 is used to derive the desired driving power to ensure vehicle operation.

V. ELECTRICAL PROPULSION SYSTEM

The block diagram of the open loop control system used to adjust the speed of the vehicle. The hardware includes squirrel cage induction motor, bridge inverter, isolation card, Digital Signal Processor (DSP), speed sensor, potentiometer for

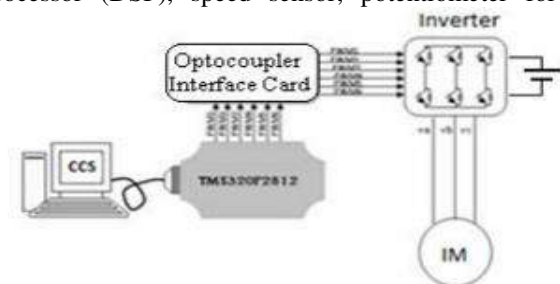

VI. OPEN LOOP CONTROL STRATEGY

The user adjusts the desired speed using a potentiometer and this latter converts it to its analogous voltage. The output of the potentiometer is sensed by the ADC which is integrated on the DSP and then converted to desired frequency F_s . The open loop control program consists of several stages as shown in the flow chart depicted in figure 6. Based on the figure, the open loop system can be summarized as follows: x Initialization DMC modules and declare variables; x Determine V_s voltages with constant V/F profile based on desired frequency (F_s) using VHz_PROF module; x Determine the time durations T_a , T_b and T_c based on V_s and F_s using SVGEN_MF module; x Generate the signal PWM based on the time durations T_a , T_b and T_c using PWMGEN module. First, confirm that you have the correct template for your paper size. This template has been tailored for output on the A4 paper size. If you are using US letter-sized paper, please close this file and download the file "MSW_USltr_format".

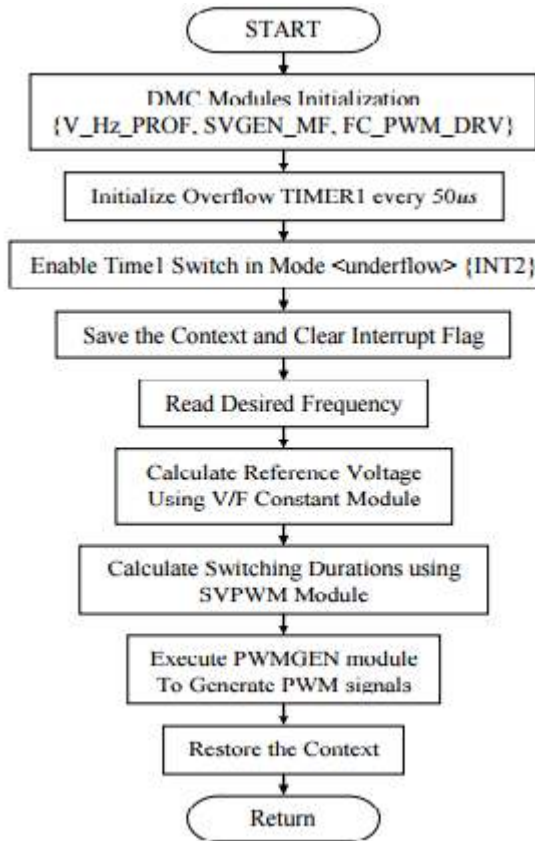

VII. PRACTICAL RESULTS

Figure 7 shows a snapshot of PWM signals generated by the SVPWM module after the execution of the program implemented in the DSP. Figure 8 illustrates the two PWM pulses which are complementary and used to trigger the gates of one leg of the IGBT Bridge of the inverter. As shown in figure 8, in order to avoid the short circuit of inverter power supply, we introduced a time delay of $0.5\mu\text{s}$ between the two complementary pulses.

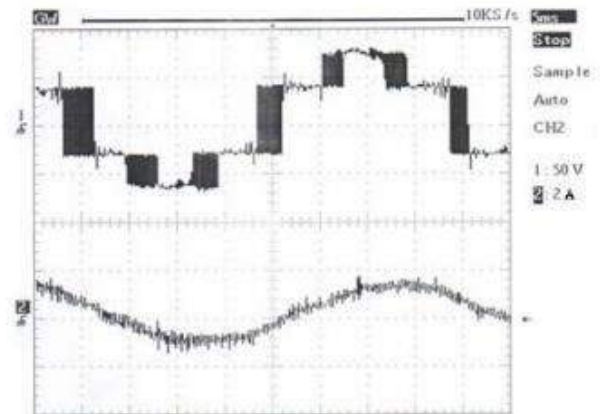
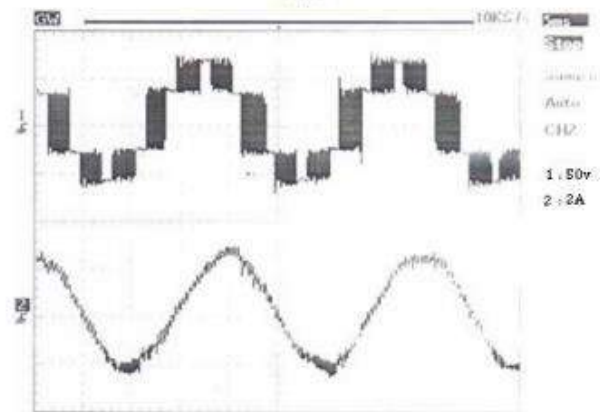

Fig. 11. Wave form of the phase voltage and current for $f=25\text{Hz}$ with a load torque



PWM signals before and after the optocoupler card which ensures galvanic isolation between DSP and Inverter. As shown in figure 9, the PWM signals of magnitude 3.3 volts generated at the DSP output are inverted and amplified to 5 volts by the optocoupler card before inputting them to the inverter. To check the switching behavior and the reliability of the inverter (i.e. IR IRAMY20UP60B module), the operation of one of its cell during commutation is investigated. Figure 10 illustrates the waveforms of current and voltage of one IGBT cell under RL inductive load ($R = 8.4\Omega$ and $L = 4.75\text{mH}$) during commutation. The switching frequency of the IGBTs transistors and DC power supply voltage are 10kHz and 160V respectively. As shown in figure 10, the current increases in continuous form from 0 to 5A during switching off (Switch Open) and then decreases back to 0A during switching on (Switch Close). The voltage across the switch is equal to the DC power supply. Figure 10 shows small current spikes and voltage ringing during switching which are probably due to the IGBTs internal parameters effects. The inverter is tested to supply induction motor with rating 4.7kW with and without load. This motor is the one selected to be used in the propulsion system designed. The switching frequency of the IGBTs transistors and DC power supply voltage are

10kHz and 200V respectively. Results illustrated in figures 11 and 12 shows the line to neutral voltage and current at the inverter output when supplying the motor. As can be noticed, the results are very satisfactory and the current wave is almost sinusoidal. Figures 11 and 12 also shows the ability of

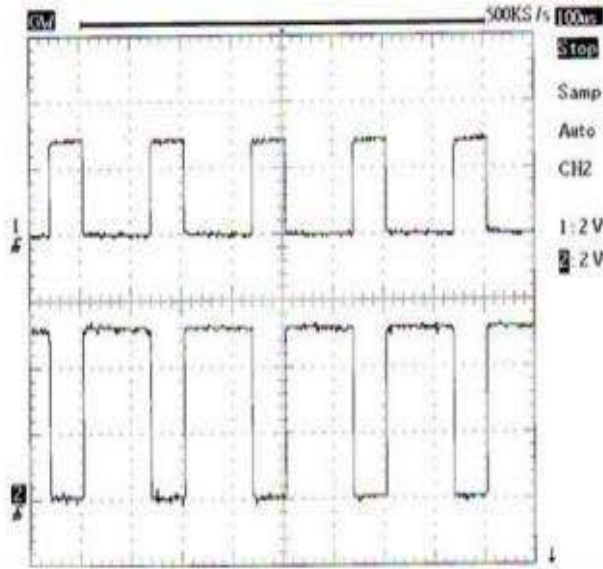

Fig. 9. PWM signals before and after optocouplers



the inverter changing speed of the motor (i.e. vehicle) by generating sinusoidal voltage for different desired frequencies (i.e. 25Hz and 50Hz). Finally, the practical performance of the electric propulsion system designed operating under road load conditions is investigated. The vehicle has been operated on a flat road and started changing its speed at different stages. The results obtained are very satisfactory as shown in figure 13. The speed is increased progressively by the driver and the maximum speed reached is more than 60km/h (i.e. 19.5m/s) and the current required at this speed is 3.5A. The results show that the vehicle can reach speed up to 90km/h.

However, driving at this speed resulted in lot of vibrations of the vehicle. This is probably due to the incomplete design requirements of the vehicle body [11]. The capability of the electric propulsion system under overload was also investigated by operating the vehicle on graded road condition where the road grade angle is about 45 degree. The results are shown in figure 14. The speed reached in this case is about 12.7m/s (i.e. 45km/h) and the current required is 5.8A.

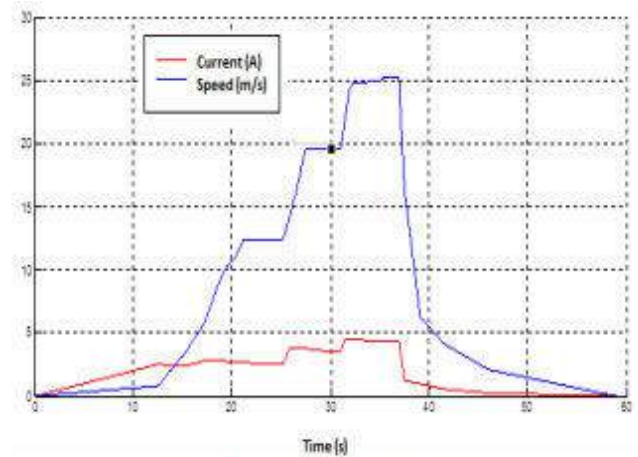
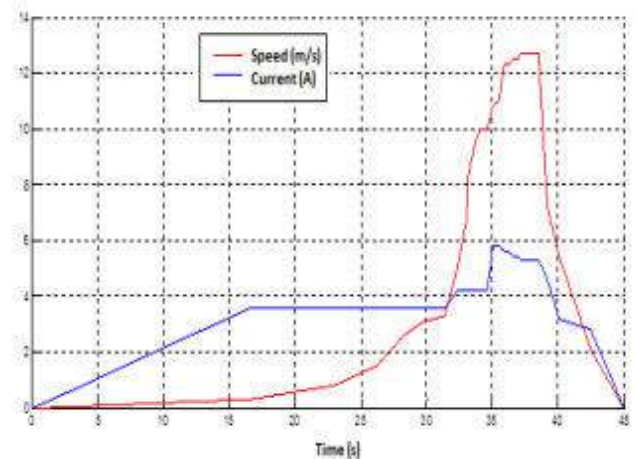

Fig. 13. Running the vehicle in flat road



VIII. CONCLUSIONS

This paper presented design of a certain part of an electric vehicle. The electric vehicle is propelled by three phase cage induction motor and powered by batteries which are charged by solar energy station. After several experiment performed, the DSP-based control system proposed and developed in this paper is able to operate the vehicle at different speeds under flat and uphill road conditions. However, during uphill condition the current required was quite high compared to current supplied to DC motor used on the same vehicle under the same condition.

Therefore, to be comparable to DC motor, more research work is required on control strategies in order to improve the performance of induction motor used in EV. Due to its low cost, robustness, high reliability and free from maintenance, automobile industry will certainly select cage induction motor as the most appropriate candidate for EVs [3]. Hence, it is believed that the work carried out will contribute in development of future electric vehicles based on the use of squirrel cage induction motor.

REFERENCES

- [1] M. Ehsani, Y. Gao, S.E. Gay, A. Emadi, "Modern Electric, Hybrid Electric, and Fuel Cell Vehicles-Fundamentals, Theory, and Design". CRC press, 2004.
- [2] H. Saidi, "Study and Realization of Solar Vehicle", Europe University Edition, Germany, ISBN : 978-613-1-55909-9 9 (in french), 2014.
- [3] H. Cheng, X. Gong, Y.F. HU, Q.F. LIU, B.Z. GAO, H.Y. GUO, "Automotive Control : The State of the Art and Perspective", Acta Automatica Sinica, Vol. 39, No. 4, pp. 322-346, 2013.
- [4] M.H. Rashid, "Power Electronics : Circuits, Devices, and Applications", 3rd Edition, 2004.
- [5] M.A. Llor, "Commandedirecte de couple à fréquence de modulation constante des machines synchrones à aimants permanents", Thèse de doctorat, université INSA, Lyon, France. 2003.
- [6] G. El-Saady, E.A. Ibrahim, M. Elbesealy, "V/F Control of Three Phase Induction Motor Drive with Different PWM Techniques", Innovative System Design and Engineering, IISTE, Vol. 4, No. 14, pp. 131-144, 2013.
- [7] M.A.A. Badran, A.M. Tahir, W.F. Faris, "Digital Implementation of Space Vector Pulse Width Modulation Technique Using 8-bit Microcontroller", World Applied Sciences Journal 21, pp. 21-28, 2013.
- [8]<http://www.alldatasheet.com/datasheetpdf/pdf/82578/TI/TMS320F2812.html>
- [9] V.M. Yashasvi, B. Amarapur, "Digital Signal Processing Based Speed Control of Induction Motor Drive System", International Journal on Advanced Electrical and Electronics Engineering, (IJAEED), Vol. 1, No. 1, 2012.
- [10] S. Soni, A. Gupta, "Analysis of SVPWM Based Speed Control of Induction Motor Drive with using V/F Control Based 3 Level Inverter", IJSET, Vol. 2, No. 9, 2013.
- [11] Alternative Energy Technical Regulations, Federation International Automobile (FIA) / Technical Department, 2006.
- [12]<http://www.irf.com/productinfo/datasheets/data/iramy20up60b.pdf>.