

# Design & Implementation of Smart Energy Meter for the Smart Grid

<sup>1</sup>G. Suresh, <sup>2</sup>N. Mangaleswari

Associate Professor/EEE, Vandayar Engineering College, Pulavarnatham<sup>1</sup>  
Asst. Professor/EEE, Vandayar Engineering College, Pulavarnatham<sup>2</sup>

## Abstract:

The demand for energy is increasing as a result of the growth in both population and industrial development. To improve the energy efficiency, consumers need to be more aware of their energy consumption. In recent years, utilities have started developing new electric energy meters which are known as smart meters. A smart meter is a digital energy meter that measures the consumption of electrical energy and provides other additional information as compared to the traditional energy meter. The aim is to provide the consumer and supplier an easy way to monitor the energy. Smart meters are considered a key component of the smart grid as these will allow more interactivity between the consumers and the provider. Smart meters will enable two-way and real-time communication between the consumers and the provider. Considering the increase of electricity demand in Saudi Arabia, smart meters can decrease the overall energy consumption. This paper presents the development of a GSM and ZigBee based smart meter. This meter can measure the energy and send the information to the service provider, who can store this information and notify the consumer through SMS messages or through the internet.

## I. INTRODUCTION

Smart meter is an advanced energy meter that measures the energy consumption of a consumer and provides added information to the utility by using a two-way communication scheme. Consumers are better informed in their consumption of their energy, so they can make better decisions when they are using the energy. Suppliers on the other hand won't need the old fashioned way of manually reading the energy consumed as they would get this information automatically. The system that utilizes one way communications to collect the data is referred to as automated meter reading (AMR) system. While the system that utilizes two-way communications with the ability to control and monitor the meters is referred to as advanced metering infrastructure (AMI) system. The combination of automatic reading and two way communication are the reason why the meter is called smart and they are also the difference between the traditional energy meter and the smart meter. The idea of AMR technology is to do the meter reading automatically and accurate. The benefit of AMR is reducing the meter cost to the supplier and billing the customers with actual meter readings. In addition, AMR will increase the accuracy of the readings and it can allow frequent reading.

Smart meters are able to send the readings over communication lines and recognize their addresses and to activate/deactivate internal modules. To have that capability, AMR requires a specific infrastructure which would make it bidirectional. Such an infrastructure is called AMI. The communication medium in an AMI system must ensure the communication between the smart meters and the central computer at the service provider. The AMI network has the ability to register meter points, communicate into the customer premises, service connecting and disconnecting and other capabilities. The communication structure can be wired like Power Line Communication (PLC) or wireless like Global n System Mobile (GSM) and IMAX. The chosen way must take into account the distances between the devices and the existing infrastructure.

GSM is a digital mobile telephony system that digitizes and compresses data before sending it.

The main advantage of the GSM is its widespread use throughout the world and the use of subscriber identity module (SIM) cards to send short message service (SMS) messages. Another new technology that smart meters are using is the ZigBee communication. ZigBee is a low-cost, low-power, wireless mesh networking standard. It is best suited for local coverage such

As Home Area Networks (HANs). ZigBee is a key technology for the smart grid considering its automated controllability of appliances, ability to control devices, and lower installation and upgrade cost. ZigBee can offer meter-to-meter communication and remote monitoring ability of whole home conditions.

Smart meter is an important component of the smart grid. Detailed load flow can be provided by such meters to the distributors so they can manage the grid effectively. Other features like recording the power quality, detecting any unauthorized access to the meter and storage capability will all help and improve the grid. Smart grid is a type of electrical grid that intelligently responds to the behavior and performance of all electric power components in order to deliver electricity services efficiently. The smart grid delivers electricity from suppliers to the consumers by using digital technologies to save energy, reduce cost and increase reliability of the system. With various studies going in the direction of smart grid in Saudi Arabia, the need for smart metering projects are essential for the success of a complete smart grid.

In this paper, the authors designed and developed a simple smart meter prototype that uses both GSM and ZigBee. The meter takes advantage of the widespread use of the GSM network with its SMS capability and the easy to use ZigBee network to send and collect the energy consumption data. ZigBee is used to communicate with other devices. Furthermore, this paper also explains how the data can be collected by the service provider and distributed to the consumers.

## II. RELATED WORK

Several studies approached the problem of designing a smart energy meter. Numerous amount of research focused on using GSM based meters. In a GSM energy meter was developed and a database that provides the information to the customer. The paper in designed a power meter based on GSM network, with the main communication way is GPRS and SMS as secondary. In a ZigBee-GSM based automatic meter reading system was developed, the meters are equipped with ZigBee that sends the data to a data collector device which uses GSM to communicate with the central computer. In addition, the paper in developed a ZigBee based smart meter that collects the data and acquire outage event data. Furthermore, research on other communication technologies for designing smart meters have been done like PLC in and Wi-Fi in.

In our work, a complete system from smart meter to data management system is developed in addition to a mobile application and a website. The smart meter is a GSM-ZigBee based developed using Adriano microcontroller. Like other GSM approaches, there is no need for external wiring as all data are transferred wirelessly. The data is provided to the user through the website, SMS and mobile application.

## III. SYSTEM OVERVIEW

The system is made up of two devices, the smart energy meter for the consumer and the receiver for the provider. The meter uses both ZigBee and GSM to send the data. The receiver also uses both technologies (ZigBee is used for testing purposes).

The overview of the system is shown in Figure above. The meter can read the energy and send it to the receiver using GSM or ZigBee. The data management system collects and stores the data and uploads it to the internet. So, the consumer can check his information from the internet using a

developed android program or through a website portal. The receiver can also send the consumption information to the user by an SMS message through the GSM network.

#### IV. DEVICE DESCRIPTION

##### A. Energy Meter

The meter consists of an Adriano Mega Microcontroller based on ATMega2560 [20], GSM modem, Bee chip, Bee shield, Regulated Power Supply, LCD Display, RS 485 Shield and a digital kWh Power Meter. The Microcontroller continuously monitors the power consumption by receiving the information from the kWh Power Meter. This meter complies with IEC 62052 and can be connected to both three or single phase loads. In addition, the kWh Power Meter communicates through a RS 485 port while the Adriano Microcontroller

Uses a USB port and a TLL UART interface. Hence, in order to communicate with the kWh meter, the RS 485 shield is needed to add a RS 485 port to the Adriano. The device sends an SMS message over the GSM Network by using the GSM modem with a SIM card; the message contains the consumption information. Another way of communication is by using the ZigBee protocol through the Bee chip for low range communication. Moreover, the energy consumption is displayed on the LCD. Also, the device was assembled inside a steel box as can be seen in Figure 2 and the schematic of the device is shown in Figure 3. The Adriano Mega has three serial communication ports. Each port has a transmitter (TX) and a receiver (RX). The three ports are connected to the GSM modem, Bee chip and the kWh meter. The kWh meter is connected through the RS 485 shield. The microcontroller sends a command through the TX and receives the information through the RX. The Adriano has to use a synchronous serial data protocol to communicate with the Bee chip. This protocol is called Serial Peripheral Interface (SPI). In this protocol, the Adriano and the Bee chip have a master slave relation. The Arduino pin MISO (Master in Slave Out) pin is used to receive data. For sending the data MOSI (Master out Slave In) is used. SCK (Serial Clock) is connected to synchronize data transmission generated by the Adriano.

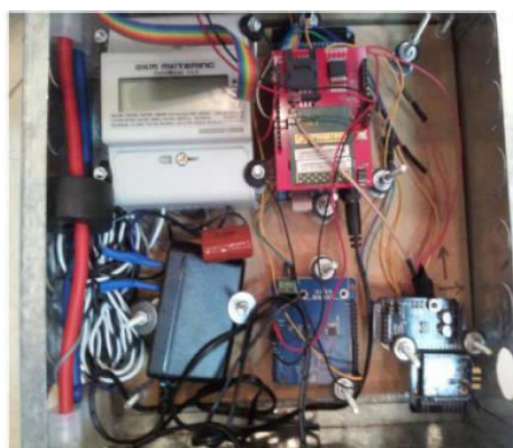
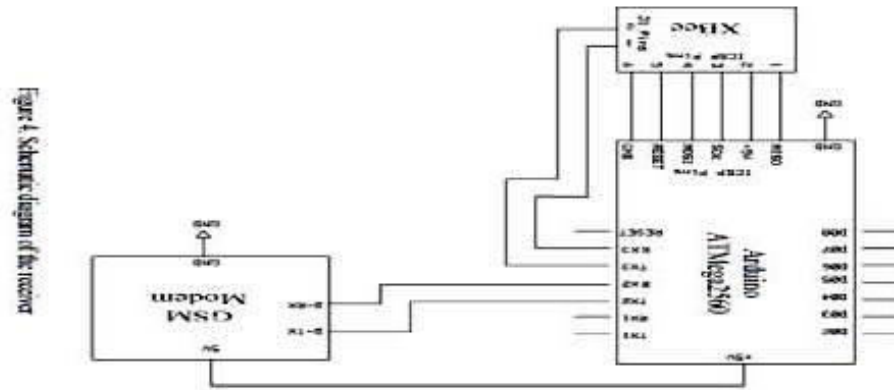

Figure 2. Components inside the steel box

##### B. Receiver

The data receiver consists of three components: Adriano Mega Microcontroller, GSM modem and a Bee chip. The device is connected to the data management system. The system will receive the data from the meter through GSM or ZigBee networks and sends it to the program. ZigBee is used

here for testing purposes because there are no available in house components that use ZigBee. The schematic of the receiver is shown in Fig 4.



## V. SOFTWARE

The software used in this project consists of two main parts, one is for the Adriano and the other is on the Pc. The Adriano microcontroller is programmed to communicate with the other components using the Adriano Integrated Development Environment (IDE) software, similar to C++. The Adriano is programmed to work as a receiver as well as a transmitter. For the PC part, two programs are developed along with a website. The first program is the data management software developed by using Visual Basic. The second program is an Android program for the mobile Phone developed using Java and Xml. The Arduino microcontroller is the main component in this device as it will have the responsibility of coordinating with the other equipment. The Arduino will receive data from the kWh Power Meter by sending a string request, and the response will be a stream of data that contains kWh, current, voltage and power factor. The Arduino program is able to extract the kWh consumption details from the stream and sends it using either the GSM modem or the Bee chip to the data management system.

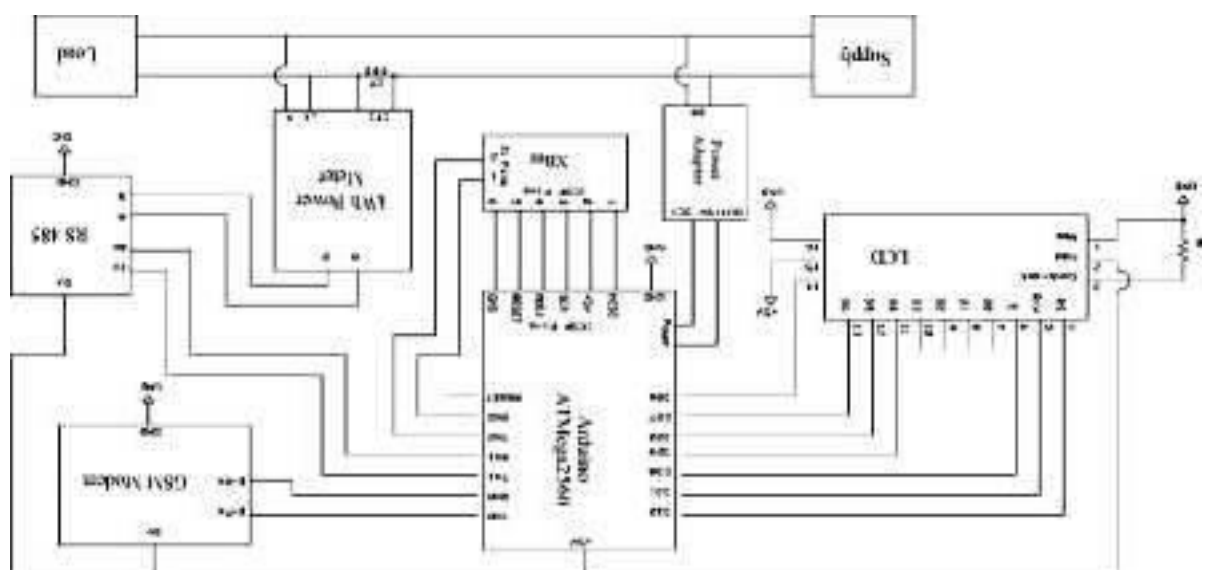

Figure 3 Schematic diagram of the smart energy meter

The data management program collects the data coming from each meter and then organizes and calculates the bills from the collected data for each consumer. This system, developed using Visual Basic, is set to act as a Meter Data Management (MDM) software. All data is uploaded to the internet so the owner can check his bill and energy consumption.

## CONSUMER INTERFACE

The Android program and the website can provide a graphical user interface (GUI) for the user to check for his information like his bills and energy consumption.

### A. Website

The website, developed using HTML and PHP, was built for the consumers to provide them with their live energy usage data and to access their detailed history. It will receive the data from the data management program every 5 minutes and graph this data to provide a visual representation of the consumer's consumption. The website is updated every 5 minutes to avoid overloading the website.

### B. Mobile

The program was developed for the Android operating system using Eclipse (Java and XML). This program can download the data from the internet to provide the user with a simple, easy and elegant way to check on this energy consumption information.

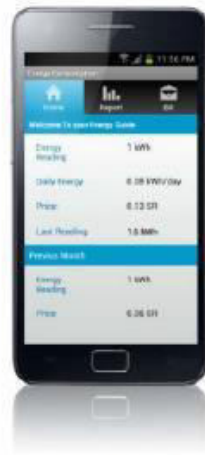

Figure 6. Snapshot of the Android program

## VI. RESULTS

The Meter developed was tested in the High Voltage Lab and the Machine lab in King Saud University, College of Engineering. In both tests the device was connected to loads and both ZigBee and GSM used in different times.

### A. High Voltage Lab Test

The device was connected to an oven such that the load draws 4 Amps at 220V. This test

lasted several hours (around 23 hours). The results are sent directly to the data management system through the GSM modem and the ZigBee.

## B. Machine Lab Test

In this Lab, a resistive load was connected to the smart energy meter for two hours. This load draws 4 Amps at 220V.

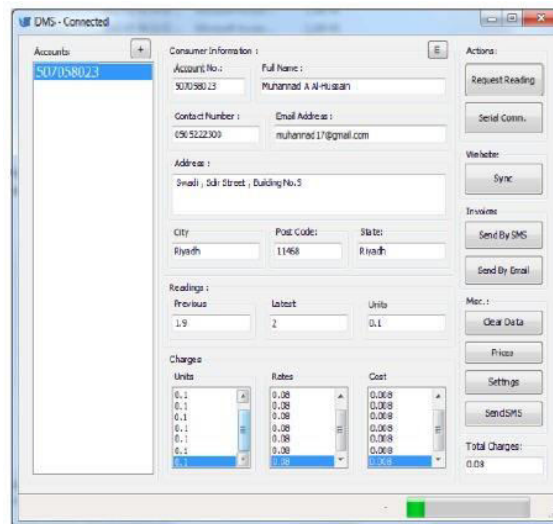

Figure 7. Results in the data management software

The results from this test were satisfactory but didn't last long because the load overheated. The microcontroller was programmed to collect the data from the kWh meter every 5 seconds. As for sending the data, Bee is set to send the data every 5 minutes and GSM sends the data every 30 minutes. The data was sent without any notable delay. Figure 7 shows the data management system receiving the data and Figure 8 shows the SMS message received by the consumer.



Figure 8. SMS message to the consumer



Figure 9. The developed device

## VII. CONCLUSION

The aim was to design and develop a device that monitors the energy consumed and then sends the data by a wireless transmission system. The data is collected by a data management system which can provide the energy usage information to the user in through the internet. The GSM and ZigBee protocols were used for wireless communication. The device works online so all the data are received in real time. In this paper, ZigBee is used by the receiver to test this technology and provide the ability to communicate with in house equipment's and other smart meters. These ZigBee features will be further exploited in future work. Other future work will consider the use of a different way for reading the energy. Also, future work will include building new prototypes and testing the device in real scenarios such as installing it in a house.

This device enables consumers to easily monitor and track their energy usage. Nowadays, people are checking their energy usage by manually reading their electricity meters, which is inefficient and provides very little information. There is a growing concern over the amount of energy consumed and the awareness of the community. By using this device, consumers will be able to use the internet or the smart phone application to monitor and economize their energy consumption. With more information people have about their energy usage, they will be able to reduce their energy Consumption and therefore save both energy and money. Figure 9. The developed device

## REFERENCES

- [1] S. Deport, W. Ling Feng, V. Devabhaktuni and N. Gaudi "Smart meters for power grid Challenges, issues, advantages and status" in Proc. Power Systems Conference and Exposition (PSCE), pp. i-7, 20-23 March 2011.
- [2] Leveraging the Full Potential of Automated Meter Reading (AMR) Technologies, GCI Group Inc., 2004
- [3] D. Hart "Using AMI to realize the smart grid" in Proc. IEEEPOIVer and Energy Society General Meeting - Conversion and Delivery on Electrical Energy, Pittsburgh, PA, pp. J- 2, July 2008.
- [4] C. Bennett and D. High fill "Networking AMI Smart Meters" in Proc. Energy 2030 Conference ire Atlanta, GA 17-18 pp. 1 - 8, November 2008.
- [5] Hurwitz and K. Wing Hung "ES6: Technologies for smart grid and smart meter," Solid-State Circuits Conference Digest on Technical Papers (sic), ire international, pp. 533, 20-24 February 2011.
- [6] G. Angelo "Wireless Mesh Networking", is edition, McGraw-Hill Professional, 2008.
- [7] M. Pope "Data collecting from smart meters in an Advanced Metering Infrastructure" in Proc. Intelligent Engineering Systems (INS), 2011 15th ire international Conference, pp. 137- 142, 23-25 June 2011.