

## CO-ORDINATION OF DIRECTIONAL AND NON DIRECTIONAL OVER-CURRENT RELAY FOR DISTRIBUTED SYSTEM

Priyanka M P<sup>1</sup>, Sathish Kumar K<sup>2</sup>

P.G. Student, Department of EEE, Priyadarshini Engineering College, Vellore, Tamil Nadu, India<sup>1</sup>

Assistant Professor, Department of EEE, Priyadarshini Engineering College, Vellore, Tamil Nadu, India<sup>2</sup>

**ABSTRACT:** Distributed generation (DG) to the power system may lead to nonselective protection actions. This paper proposes a novel method to determine the optimal set distribution network comprising of DG. Consequently, it provides to the utility planners one set of relay settings valid for different capacities of DG units varying between zero and the maximal desired capacity i.e. a method capable of optimally identifying one set of relay settings valid for all possible future DG planning scenarios. The proposed approach is tested on the distribution part of the radial test system. The protection coordination problem is formulated and is simulated in MATLAB/C-Program

**KEYWORDS:** Co-Ordination, Over-Current Relay(OCRs), Simplex method, Linear Programming, etc.

### I. INTRODUCTION

An important step in the design of any power distribution system is the time-current coordination of all over current protective devices required for the protection of the system and the connected equipment. When a short circuit or an abnormal power flow occurs for a sustained period of time, the protective devices should react to isolate the problem with minimum disruption to the balance of the system. This is the goal of a well-coordinated electrical power system

With the penetration of distributed generation(DGs) at distribution level, protection of a distribution network is quite challenging due to the change in operating mode and system topology. Thus the relay settings have to be updated every time there is a change in network configuration. This paper presents a simplex algorithm with fastest backup protection in which new optimal relay settings calculated by proposed algorithm solves the problem regarding changing of coordination time interval and critical clearing time as mode changed. This proposed algorithm uses the numerical inverse overcurrent relays which have the capability of memory storage and to cope up with communication. The proposed algorithm has been verified on test systems of different operating modes using MATLAB/Simulink. Results showed the importance and necessity of this scheme in maintaining the optimal performance of the relays

However, the previous papers have the drawback of using the protection coordination problem is formulated as a nonlinear programming (NLP) problem with both relay settings being the decision variables of the problem using sequential quadratic model[1]. The power systems with mixed integer NLP approach is presented. Finally, with respect to the formulation, deterministic or heuristic optimization techniques can be utilized to solve the protection coordination problem[2] With the current interest in smart grids, it is expected that there will be more frequent interconnection of DGs, which in such case will result in numerous changes in relay settings using

evolutionary algorithm[3].

[4]One major problem is that the optimized relay settings in such case will only be valid for those specific DG capacities. In other words, any new DG addition will require an update to the existing relay settings.[5] The studies proposed by considering a predefined DG capacity and thus any changes in the DG capacity will require modifications in the existing relay settings. With the current interest in smart grids, it is expected that there will be more frequent interconnection of DGs, which in such case will result in numerous changes in relay settings. In order to plan smart grids, taking into account future possible DGs, a different approach to the protection coordination problem needs to be developed that can plan the relay settings such that the number of changes in a protection system is minimized.

This system proposes a novel method to determine the optimal settings of the OCRs that are feasible for all possible future DG capacities. Consequently, it provides to the utility planners one set of relay settings valid for different capacities of DG units varying between zero and the maximal desired capacity. The protection coordination problem is formulated as a LP problem and is solved using the simplex algorithm. The simulations are conducted on the distribution part of the modified IEEE 14-bus system and the IEEE 13-bus radial distribution system. The structure of this system can be described as follows. First, the formulation of the optimization problem is presented and described. The following section describes the test system under study and the optimization techniques used to solve the formulated problem. Thereafter, the results of the conducted simulations are presented. The penultimate section examines the influence of the fault current limiters (FCLs) on the obtained results.

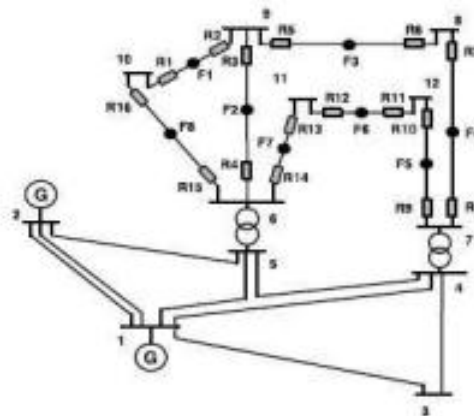

Fig 1.1. Single line diagram of the modified IEEE 14-bus system for protection coordination

## II. PROPOSED FORMULATION FOR PLANNING PROTECTIVE DEVICE SETTING

In distribution systems, the penetration level of DG usually increases gradually up to the maximum utility planned limit. Consequently, it is important to plan the settings of the protective devices that can cope with this gradual increase in DG penetration. In this system, it is assumed that the maximum planned DG capacity by the utility at location  $n$  is known and will be denoted as

$S_{DG_{max}}$ . The objective is to determine the relay settings that will maintain protection coordination among possible DG installations within  $S_{DG_{max}}$ .

$$t_{ij,s}^b - t_{ij,s}^p \geq CTI_{i,j,s}$$

where  $i$  denotes the fault location and  $j$  denotes the relay identifiers. The  $t_{ij,s}^p$  and  $t_{ij,s}^b$  are respectively the operating times of primary and back-up relay for the fault at location  $i$  and for combination  $s$  of DG capacities. The maximum limit on  $s$  will depend on the number of DG locations and the resolution by which the DG capacity is varied.

$$\text{Minimize } T_{OPR} = \sum_{i=1}^N \sum_{j=1}^M \sum_{s=1}^L t_{ij,s}^p + t_{ij,s}^b$$

where  $N$  is the set of all fault locations,  $M$  is the set of all system relays, and  $L$  is the set of all examined combinations. Furthermore, an additional set of constraints is imposed on the relay time dial settings as follows:

$$TDS_{min} \leq TDS_j \leq TDS_{max} \forall j$$

Where  $TDS_{max}$  and  $TDS_{min}$  are the upper and lower limits on the relay  $j$  time dial setting, respectively.  $TDS_{max}$  and  $TDS_{min}$  are set to 0.05 and 1, respectively. The values of the pick-up current settings are determined based on the maximum possible load current and the minimum short-circuit current passing through each relay.

### III. PROTECTION COORDINATION BY LINEAR PROGRAMMING

Linear programming (LP; also called linear optimization) is a method to achieve the best outcome (such as maximum profit or lowest cost) in a mathematical model whose requirements are represented by linear relationships. Linear programming is a special case of mathematical programming (mathematical optimization).

More formally, linear programming is a technique for the optimization of a linear objective function, subject to linear equality and linear inequality constraints. Its feasible region is a convex polytope, which is a set defined as the intersection of finitely many half spaces, each of which is defined by a linear inequality. Its objective function is a real-valued affine (linear) function defined on this polyhedron. A linear programming algorithm finds a point in the polyhedron where this function has the smallest (or largest) value if such a point exists.

The simplex algorithm, developed to solve LP problems by constructing a feasible solution at a vertex of the polytope and then walking along a path on the edges of the polytope to vertices with non-decreasing values of the objective function until an optimum is reached

### IV. FLOW CHART OF PROPOSED SYSTEM

A flowchart of the proposed approach for planning the relay settings. The parameters to be defined for the proposed algorithm include the planned maximum

DG capacity at a desired locations, DG capacity resolution and predefined pick-up current settings. Since the algorithm is designed to satisfy the various possible DG combinations within the

maximum planned capacity, the impedance matrix  $Z_{bus}$  is constructed for every  $s$  combination. Fault analysis is performed and the optimal TDS relays settings are determined using the simplex algorithm. The obtained settings can guarantee proper protection coordination for all DG sizes within the planned DG capacity. The simplex algorithm is considered one of the most popular algorithms used for solving LP problems. The constraints applied to the objective function form a convex polytope which determines the feasible region. The optimal solution is located at one of the polytope's vertices. The specific vertex and searches along the edges of the polytope until it converges to the optimal solution. It is worthy to note that the proposed approach considers three phase bolted faults while planning for the relays settings.

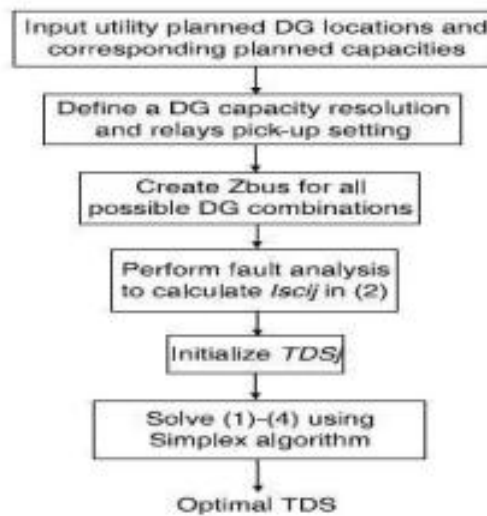

Fig 3.1 Flow chart of proposed system

## V. SIMULATION AND RESULTS

Simulation are presented in this section to high-light the advantages of the proposed approach. For the protective devices are optimally coordinated considering only the maximum planned DG capacities. On , the second takes into account possible combinations of DG capacities within the maximum planned amount (the proposed approach) The protection coordination problem is formulated and is simulated in MATLAB/C-Program

It is worthy to note that radial systems are typically protected by OCRs or fuses. The addition of DG will result in a bidirectional flow of fault current. Thus, the protection system, in this system, has been modified and certain sections of the test system, depending on the DG location, are protected with OCR

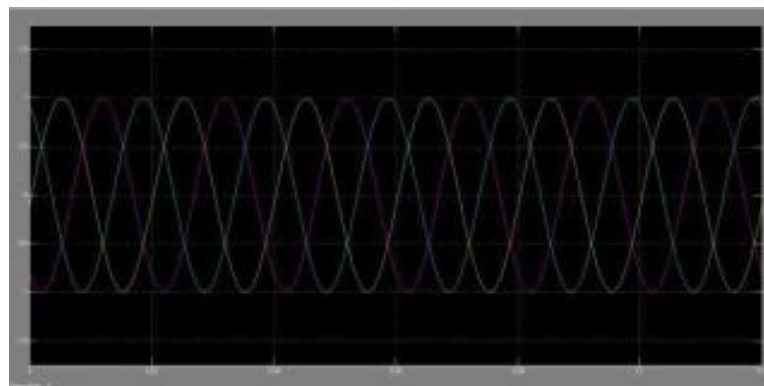

Fig 5.3 Output Waveform of Bus System

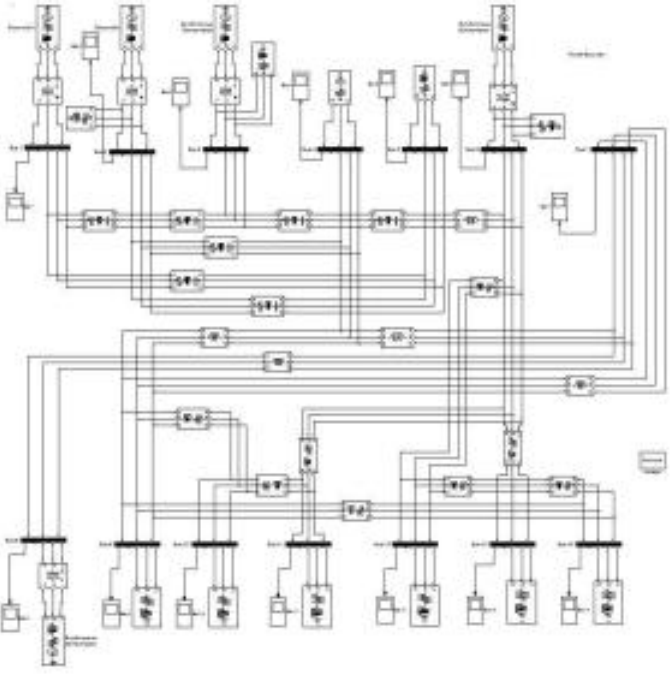

Fig 5.2 Simulation Diagram for IEEE 14 and 13-bus System

```
1.0e+02 *  
0.0100 + 0.000001  
0.3711 + 0.06671  
0.7322 + 0.13331  
1.0933 + 0.20001  
1.4544 + 0.26671  
1.8155 + 0.33331  
1.4544 + 0.26671  
1.8155 + 0.33331  
1.8155 + 0.33331  
2.1766 + 0.40001  
2.5377 + 0.46671  
2.1766 + 0.40001  
2.5377 + 0.46671  
2.8988 + 0.53331  
  
3.0000 + 0.00001  
2.0000 -10.83301  
  
24-Nov-2015 11:06:13  
Elapsed time is 0.318131 seconds
```

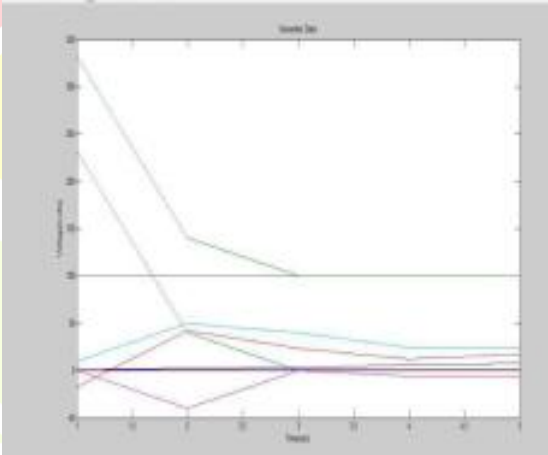

Fig 4.3 Waveform of Generator Data

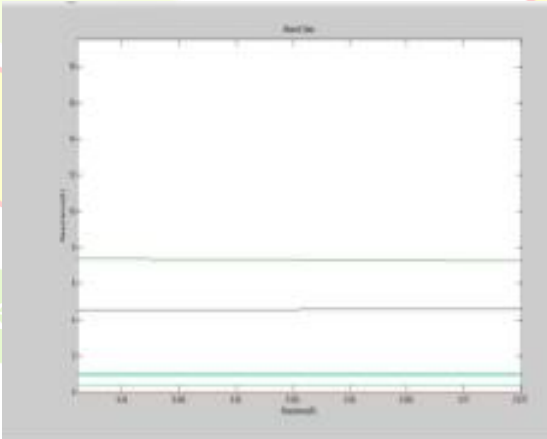
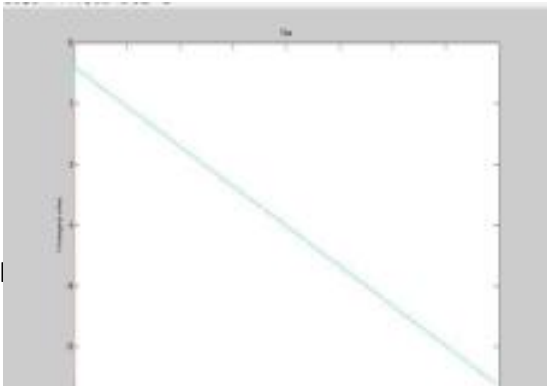

Fig 4.4 Waveform of Bus Data



All

Fig 4.7 Y-Bus Data Waveform

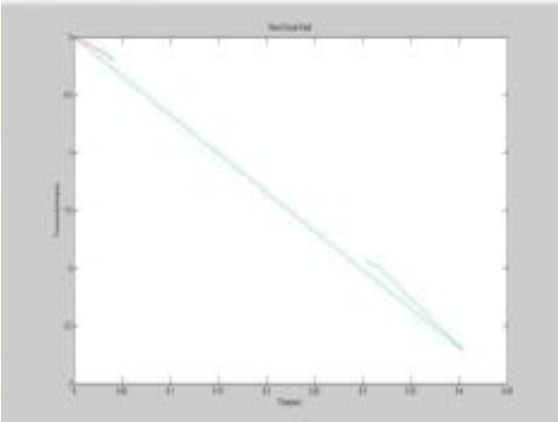

Fig 4.8 Waveform of Short Circuit Fault

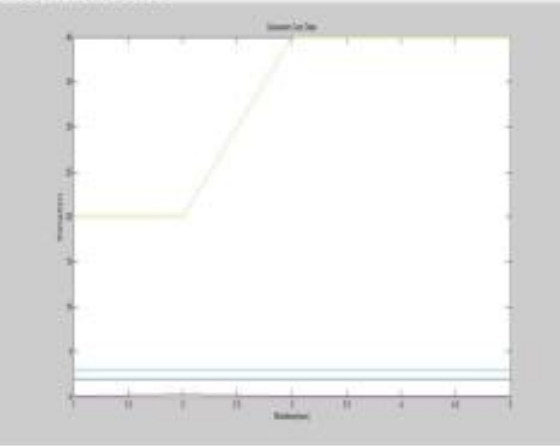

Fig 4.5 Waveform of Generator Cost

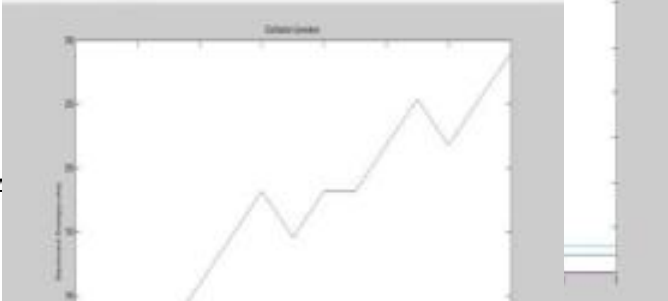

Fig 4.6 Newly added Distribution Generator Waveform

## VI. CONCLUSION

The DG penetration increases with time possible violation in protection coordination can occur requiring frequent changes in relay settings. The proposed method avoids this problem by incorporating constraints that can guarantee protection coordination for DG capacities up to the maximum planned value (and not just for the rated value). By utilizing the proposed method and optimally allocating a FCL, one set of relay settings can be planned that can guarantee protection coordination up to the planned DG capacity while minimizing the overall relay operating time.

Distributed Generator is a small capacity generator, whose size varies from 10 kW to 15 MW. While considering renewable source as the source for the DG, the output varies continuously. Because of this variable output change the relay settings have to be changed for the system often therefore Co-ordination of directional over-current relay is done while considering DG

The proposed approach is tested on the distribution part of the radial test system is tested using Industrial Bus System. Protection equipments are coordinated with each other so that when fault occurs only the corresponding relay sends the trip signal and other relay remains idle. Selective fault isolation is provided. Outage possibility of the system is minimized. Limits the extend and duration of service interruption. Fault clearing time is maximized

## REFERENCES

- [1] A. H. Askarian, M. Al-Dabbagh, K. H. Kazemi, H. S. S. Hesameddin, and R. A. J. -Khan, "current relays in interconnected *IEEE Power Eng.Rev.*,vol.22, nopower.6,.60,Jun .systems,"2002
- [2] D.Birla, R.Maheshwari, irectional and OverH.CurrentGupta,relaycoordination"A technique,new and nonlinear banes and boons of near- end faults based *IEEETrans. Powerapproach*,"*Del.vol.21,no.3*, 1176–1182, Jul. 2006
- [3] A.Urdaneta, R.Nadira, and L. P. JimenCurrentenz, relays"Optimalin coordination interconnect *IEEE Trans. Power Del.*, vol. 3, no. 3, pp. 903–911, Jul. 1988
- [4] B. Chattopadhyay, M. Sachdev,-linea relay coor-dinationandalgorithmT. For Sidhu, adaptiveprotection"Anusing onlinear programming technique,"*IEEE Trans. Power Del.*, vol.



- 11, no. 1, pp. 165–173, Jan. 1996.
- [5] H. Laaksonen, D. Ishchenko, and A. Oudalov, “Adaptive *IEEE Trans. Smart protection Grid*, vol. 5, no. 3, pp. 1486–1493, May 2014
- [6] M. M. Mansour, S. Mekhamer, and N.-S. El-Kharbawe, “A modified particle swarm optimizer-rent relays,” *IEEE Trans. Power Del.*, vol. 22, no. 3, pp. 1400–1410, Jul. 2007
- [7] C. W. So and K. K. Li, “Time coordination method *IEEE Trans. for Ind. Appl. power*, vol. 36, syste no. 5, pp. 1235–1240, Sep. 2000.
- [8] R. Chabanloo, H. Abyaneh, A. Agheli, and considering H. transient Rastegar, behavior of fault current “Over Current limiter and distributed generation *IET Gener. Transmissin. Distrib* distribution., vol. 5, no. 9, pp. 903–911, power Sep. 2011 network,”
- [9] H. Yazdanpanahi, Y. W. Li, and mitigate W the impact Xu, of inverter “A-based new control DG on l strategy protection *IEEE to Trans. Smart Grid*, vol. 3, no. 3, pp. 1427–1436, Sep. 2012.
- [10] H. H. Zeineldin, Y.-R. Mohamed, V. Khadkikar, -tection coordination and index V. for evaluating Pandi, distributed “A generation pro impacts on protection for meshed *IEEE Trans. Smart distribution Grid*, vol. 4, no. 3, pp. 1523 systems,” –1532, Sep. 2013

